



01. STEAMitUp Toolkit

Prepared by CARDET



Contents

Introduction to the STEAMitUp Toolkit	4
Overview of the Best Practices and OERs	5
Best Practice 1. STEM/ Girls Education	7
Best Practice 2. Science Fun	9
Best Practice 3. Girls into Global Stem (GIGS).....	12
Best Practice 4. Guidelines for Developing and Implementing STEAME Schools.....	14
Best Practice 5. Mathematics and Science for life.....	16
Best Practice 6. Bebras Challenges	20
Best Practice 7. Irish Girl Guides Innovatively Engaging with STEM.....	23
Best Practice 8. DCU - Learn it Academy	24
Best Practice 9. STEM Teacher Internship programme	26
Best Practice 10. STEAM4U - Raising students perceived self-efficacy in STEAM	29
Best Practice 11. Math & Art in Athens	31
Best Practice 12. Ypatia – Expect Everything.....	33
Best Practice 13	36
Best Practice 14. Smart Kids Lab	38
Best Practice 15. ROOTS: A community-based, multilingual STEAM program	39
Best Practice 16. Community Art project with crafted neurons.....	42
Best Practice 17. Google Arts and Culture: Experience culture in 360°	46
Best Practice 18. Codecademy.....	48
Best Practice 19. Scratch.....	49
Best Practice 20. Create your own videogame using Scratch.....	50
Best Practice 21. Resources for Teachers of all STEAM subjects.....	51
Best Practice 22. STEM Learning.....	53

Best Practice 23. Resilient Educator	55
Best Practice 24. BBC micro:bit Educational Foundation	56
Best Practice 25. Science For Fun	58
Overview of the Lesson Plans (Learning activities).....	60
Cyprus	62
Lesson 1: Coding and Programming	62
Lesson 2: Geometry – Relationships between edges, vertices and peaks	64
Greece	62
Lesson 3: Spread of Virus and Face Masks Creation	67
Lesson 4: Balloon Tower Challenge	74
Spain	78
Lesson 5: STEAM Females	78
Lesson 6: STEAM Concepts -Programmed.....	85
Netherlands	91
Lesson 7: Build your own Salt Sculpture	92
Lesson 8: Colourful kitchen chemistry	98
Ireland	108
Lesson 9: Basic HTML	108
Lesson 10: Basic knowledge about Scratch	110
UK.....	113
Lesson 11: The Great Fire of London	113
Lesson 12: Solar Snacks	119
Overview of the Educational Materials and Resources.....	127

Introduction to the STEAMitUp Toolkit

This practical and innovative Toolkit is an easy-to-use package of resources, that is anticipated to support teachers to develop, design and implement effective activities for enhancing basic skills to students within STEAM education. The target audience involves STEAM experts and practitioners, educators and trainers, students, teachers of primary and secondary school level. This toolkit is developed based on the results and recommendations of the prior research that has been conducted by the consortium (see Transnational Report). The objective of this Toolkit is to provide STEAM education providers, teachers and educators with a comprehensive illustration of STEAM education theoretical framework. It consists of X interconnected sections, covering all the subjects that arose from the preceded extensive desk research. These include best practices, OERs', class activities (lesson plans), strategies, methods, technological tools and materials (i.e. robotics tools, digital and other non-digital tools) that are used in the partner countries and in the EU for promoting STEAM education for the development of



digital skills, critical thinking, collaboration and problem - solving techniques to students of elementary and secondary level.

The first part of the toolkit will allow for the first time to obtain a holistic overview of the state of the art on STEAM education tools and developments, will allow for the identification of those which are most suited to the project purposes and which can be integrated into the STEAMitUp training implementations. Currently no comprehensive overview exists, and even though there is a mass of information available.

The second part of the toolkit presents a list of 25 best practices which have been identified as a result of an extensive desk research that has been conducted by the STEAMitUp consortium.

The last part of the toolkit showcases the materials and resources that have designed and developed during the implementation of the lesson plans, workshops and school days events across the six EU participated countries.

Overview of the Best Practices and OERs

In an effort to promote STEAM education across EU and beyond, a list of 25 best practices have been identified as a result of an extensive desk research that has been conducted by the STEAMitUp consortium. The list of BPs' is presented in a tabular format and consist of various EU exemplars including strategies, methods, technological tools, applications and materials that can be used to cultivate students' digital skills (such as problem-solving, critical thinking and collaboration).



Best Practice 1	
1. Topic/ Area	STEM/ Girls Education
2. Title	STEM
3. Type of Best Practice	<ul style="list-style-type: none"> ✓ Online Training Curriculum in STE(A)M learning and gender sensitive practices. ✓ Report on the value of STE(A)M in Girls' education ✓ Digital Teacher's Toolkit (DTT) with STE(A)M activity kit for primary school ✓ European Charter for STE(A)M Education and Impact report
4. Date released	2019
5. Partners/ network	<ul style="list-style-type: none"> ✓ CESIE [Coordinator], Palermo, Italy, www.cesie.org ✓ Danmar Computers LLC [Partner], Rzeszów, Poland, www.danmar-computers.com.pl ✓ INOVA+ [Partner], Porto, Portugal, www.inova.business ✓ Four Elements [Partner], Athens, Greece, www.4-elements.org ✓ CARDET [Partner], Nicosia, Cyprus, www.cardet.org ✓ DOĞA SCHOOL [Partner], Istanbul, Turkey, www.dogakoleji.k12.tr ✓

6. Description of the methods/ approach	STE(A)M is an educational approach to learning that uses Science, Technology, Engineering, the Arts and Mathematics as access points for guiding student inquiry, dialogue, and critical thinking and the acquisition of these competences. It incorporates gender-inclusive teaching methods and open resources focused on STE(A)M learning in primary education; to foster creativity, critical thinking and problem-solving competences among young pupils in STEM.
7. Purpose/Aim	The current best practice aims to increase the competence development of teachers and educators, to increase and nurture girls' interest in STEM fields and support the interest in STEM disciplines.
8. Evaluation (results) of its effectiveness (if applicable)	N/A
9. Overview of the lessons learned which are relevant to the project	N/A
10. Web link	https://in2steam.eu/

Best Practice 2	
1. Topic/ Area	Science Education
2. Title	Science Fun
3. Type of Best Practice	<ul style="list-style-type: none"> ✓ Guidelines and ideas for designing learning activities ✓ Piloting the toolkit in all countries: Case studies ✓ Collection of Best Practices for Making Learning Science ✓ Recommendations for utilising comics, mobile devices, digital storytelling, and social media
4. Date released	2015
5. Partners/ network	<p>Project Co-ordinator: The Group for European Integration (GIE), www.gie.ro</p> <p>Project partners:</p> <ul style="list-style-type: none"> ✓ Louth Meath Education and Training Board – LMETB, https://www.lmetb.ie/ ✓ University of Pitesti (UPIT), https://www.upit.ro/ ✓ CARDET, https://www.cardet.org/ ✓ The University of the Peloponnese, http://www.uop.gr/ ✓ University of Lodz, https://iso.uni.lodz.pl/ ✓ INNOVADE LI (InnovADE), http://www.innovade.eu/
6. Description of the methods/ approach	<p>This project proposed that an approach to enhancing student interest for science can be conceptualized through the design of science curriculum materials that focus on making</p>

	<p>learning science fun, by supporting personalized, meaningful, situated, and contextual learning.</p>
<p>7. Purpose/Aim</p>	<p>The aim of the project was to address the challenge of engagement in science through an innovative approach to science teaching and learning and make learning science Fun and Relevant to students' contexts. The project aimed to increase pupils' motivation and achievement in science and other subjects and to prepare European educators to better engage pupils in science education. Mainly, the aim of SciFuN is to develop an online toolkit, which will be composed of the following sections:</p> <ul style="list-style-type: none"> • Prepare European educators to better engage pupils in science education. • Prepare European educators to better engage pupils in science education. • Describe general approaches and specific methods and techniques to teach key competences and concepts in Science and other important areas of the curriculum. • Support educators in utilizing mobile devices (GPS, PDAs, Tablet PCs), comics, digital storytelling, film, multimedia, and Web 2.0 technologies to engage students in Science education. • Support educators in utilizing mobile devices (GPS, PDAs, Tablet PCs), comics, digital storytelling, film, multimedia, and Web 2.0 technologies to engage students in Science education. • Support educators in utilizing mobile devices (GPS, PDAs, Tablet PCs), comics,

	digital storytelling, film, multimedia, and Web 2.0 technologies to engage students in Science education.
8. Evaluation (results) of its effectiveness (if applicable)	For research and dissemination check here https://www.scifun.eu/index.php/en/outputs
9. Overview of the lessons learned which are relevant to the project	Produced Global STEM Challenges linked to the UN Global Goals (also known as the Sustainable Development Goals)
10. Web link	https://www.scifun.eu/index.php/en/
11. References/ online sources	https://www.scifun.eu/index.php/en/

Best Practice 3	
1. Topic/ Area	STEM/ Girls Education
2. Title	Girls into Global Stem (GIGS)
3. Type of Best Practice	<ul style="list-style-type: none"> ✓ Intellectual Output 1: Global STEM Challenges ✓ This was the focus in Year 1 leading to the development of innovative methodologies and the students' eBooks ✓ Intellectual Output 2: Teacher Training Materials. We are developing teacher training in a variety of formats including an online course ✓ Intellectual Output 3: Teacher Toolkit See www.gigstoolkit.com for further details ✓ Intellectual Output 4: Training Curriculum
4. Date released	2016
5. Partners/ network	<ul style="list-style-type: none"> ✓ Project Co-ordinator: The University of Hull (UK) <p>Project partners:</p> <ul style="list-style-type: none"> ● Practical Action (UK) ● Centre for Citizenship Education (PL) ● Centre for Advancement of Research and Development in Educational Technology Ltd-CARDET (CY) ● University of Boras (SE) ● de Ferrers Academy (UK) ● Zespół Szkół w Siennicy (PL) ● The Grammar School, Nicosia (CY)

	<ul style="list-style-type: none"> • Sandgårdskolan (SE)
<p>6. Description of the methods/ approach</p>	<p>The project developed innovative methodologies such as sustainable development goals, climate action and more as well as the students' eBooks which are available here</p> <p>http://gigstem.weebly.com/io1-global-stem-challenges.html</p>
<p>7. Purpose/Aim</p>	<p>The “Girls into Global STEM” (GIGS) project aims to increase the employment potential of all young Europeans, but especially girls, by improving their interest and engagement in STEM subjects through linking these to a wider awareness of global issues. More precisely, the objectives of this project were:</p> <ul style="list-style-type: none"> • To increase the employment potential of young Europeans, especially girls, by improving their interest and engagement in STEM linked with wider awareness of global issues and facilitated through digital skills. • To support teachers in the embedding of digital skills and global learning methodologies into their STEM teaching • To integrate digital literacy set within a global context into STEM education policy and practice
<p>8. Evaluation (results) of its effectiveness (if applicable)</p>	<p>For research and dissemination check here</p> <p>http://www.gigstoolkit.com/research-and-dissemination.html</p>

9. Overview of the lessons learned which are relevant to the project	Produced Global STEM Challenges linked to the UN Global Goals (also known as the Sustainable Development Goals)
10. Web link	www.gigsproject.eu

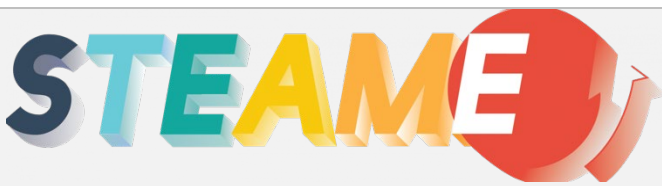
Best Practice 4	
1. Topic/ Area	“STEAME” Science, Technology, Engineering, Arts, Mathematics and Entrepreneurship”
2. Title	STEAME: Guidelines for Developing and Implementing STEAME Schools”
3. Type of Best Practice	<ul style="list-style-type: none"> • Guidelines for dynamic and adaptive STEAME curricula • Guidelines for STEAME Activities in Schools for two age groups • Guidelines for STEAME School Organizational Structure
4. Date released	2019
5. Partners/ network	<p>Coordinating Organization</p> <p>Cyprus Mathematical Society - Cyprus</p> <p>Partners</p>

	<ul style="list-style-type: none"> • Cyprus Pedagogical Institute - Cyprus • Pedagogical University of Krakow - Poland • Prof. Ivan Apostolov Private English Language School - Bulgaria • Institute of Accelerating Systems and Applications (IASA) - Greece • Douka Ekpaideftiria AE-Palladion Lykeion-Doukas School - Greece • ITC Pacle Morante Limbiate - Italy
6. Description of the methods/ approach	N/A
7. Purpose/Aim	The project intends to develop a prototype school structure design with suggested dynamic curriculum, activities, learning and creativity plans and methods, developing also a training course for training teachers on how they can work effectively and productively under a STEAME school.
8. Evaluation (results) of its effectiveness (if applicable)	Journal of STEAME Creations for and by School students https://steame.eu/journal-of-steame-creations-for-and-by-school-students/
9. Overview of the lessons learned which are relevant to the project	N/A
10. Web link	www.steame.eu
11. References/ online sources	https://steame.eu/news/

Best Practice 5	
1. Topic/ Area	Science, Mathematics education, General education and e-learning.
2. Title	Mathematics and Science for life
3. Type of Best Practice	mascil toolkit Toolkit for teacher PD The World of Work IBL & WoW in classroom mascil final conference Educating the Educators II

	Teachers' e-learning platform platform, which hosts e-learning courses for teachers
4. Date released	2013
5. Partners/ network	<p>thirteen countries represented by the partner universities and institutes of mascil:</p> <p>University of Education Freiburg, Germany http://mascil.ph-freiburg.de</p> <p>Utrecht University, Netherlands http://www.projects.science.uu.nl/mascil/</p> <p>University of Jaén, Spain http://www.ujaen.es/investiga/mascil</p> <p>Norwegian University of Science and Technology (NTNU), Norway http://mascil-norge.org</p> <p>Hacettepe University, Turkey http://www.mascil.hacettepe.edu.tr/</p> <p>Babes-Bolyai University, Romania http://simplexportal.ro/mascil-project.ro</p> <p>University of Hradec Králové, Czech Republic http://ris.uhk.cz/mascil/</p> <p>Divulgación Dinámica S.L. (Dynamic Disclosure S.L.), Spain http://www.ujaen.es/investiga/mascil</p> <p>University of Vienna, Austria http://mascil.science-edu.at</p> <p>Vilnius University, Lithuania http://ims.mii.lt/mascil</p> <p>The University of Nottingham, Great Britain http://www.nottingham.ac.uk/research/groups/crme/projects/mascil.aspx</p>

	<p>National and Kapodistrian University of Athens, Greece http://noether.math.uoa.gr/mascil</p> <p>Foundation for Research and Technology Hellas, Greece http://noether.math.uoa.gr/mascil</p> <p>University of Münster, Germany http://mascil.ph-freiburg.de</p> <p>EDEX-Educational Excellence Corporation Limited, Cyprus http://www.mascil-cyprus.org/</p> <p>Institute of Mathematics and Informatics at the Bulgarian Academy of Science, Bulgaria http://www.math.bas.bg/omi/mascil/index.html</p> <p>University of Kiel, Germany http://mascil.ph-freiburg.de</p>
6. Description of the methods/ approach	The project employed inquiry-based learning (IBL) as the main method which is defined as being inductive, student-centered and focused on creativity and collaboration (Doorman, 2011). IBL aims to develop and foster inquiring minds and attitudes that are vital for students to face and manage uncertain futures and learning is driven by open questions and multiple-solution strategies.
7. Purpose/Aim	Mascil aims to promote a widespread use of inquiry-based science teaching (IBST) in primary and secondary schools. The major innovation of mascil is to connect IBST in school with the World of Work (WoW) making science more meaningful for young European students and motivating their interest in careers in science and technology.
8. Evaluation (results) of its effectiveness (if applicable)	Read the report about the evaluation results:  Report about the formative and the summative evaluation of the project

	https://mascil-project.ph-freiburg.de/research/evaluation.html
9. Overview of the lessons learned which are relevant to the project	Teachers PD https://mascil-project.ph-freiburg.de/professional-development.html Classroom material/ Repository: http://www.fisme.science.uu.nl/publicaties/subsets/mascil/
10. Web link	https://mascil-project.ph-freiburg.de/
11. References/ online sources	For publication visit https://mascil-project.ph-freiburg.de/contact.html Doorman, M. (2011). PRIMAS WP3 – Materials: Teaching and professional development materials for IBL (version 2). Netherlands.
12. Additional notes	Activities and Events: https://mascil-project.ph-freiburg.de/activities/activities-events.html

Best Practice 6	
Topic/ Area	Science, Technology, Engineering, Arts & Maths
Title	Bebras Challenges (Ireland)
Type of Best Practice	Online Tools, Applications or Platform
Date released	Annual Irish Competition started 2012 (International Bebras challenge started in Lithuania in 2004)
Partners/ network	Irish Computer Society, Ireland (as part of the wider Bebras Community)
Description of the methods/ approach	<p>Computational thinking involves using a set of problem-solving skills and techniques that software engineers use to write programs and apps.</p> <p>The Bebras challenge promotes problem solving skills and Informatics concepts including the ability to break down complex tasks into simpler components, algorithm design, pattern recognition, pattern generalisation and abstraction.</p> <p>The second week of November is declared as World-Wide BEBRAS week for solving tasks. Some countries extended it to two weeks. Many countries run all-year-round Bebras activities like participants awarding events, second round of the challenge, summer campus, teacher workshops, collecting statistics and writing research papers.</p> <p>The Bebras challenges are made of a set of short problems called Bebras tasks and are delivered online. The tasks are fun, engaging and based on problems that computer scientists often meet and enjoy solving. The tasks can be solved without prior knowledge but instead</p>

	require logical thinking. The aim is to solve as many as you can in the allotted time.
Purpose/Aim	<p>Bebras is an international initiative aiming to promote Informatics (Computer Science, or Computing) and computational thinking among school students at all ages.</p> <p>Participants are usually supervised by teachers who may integrate the Bebras challenge in their teaching activities. The challenge is performed at schools using computers or mobile devices.</p> <p>We emphasise participation but also recognise top performing students. All countries provide different types of certificates available to students in each age group, for example, Certificate of Participation, Certification of Merit, Certificate of Distinction etc.</p>
Evaluation (results) of its effectiveness (if applicable)	N/A
Overview of the lessons learned which are relevant to the project	<p>The questions are in the form of engaging puzzles that start off relatively easy so every student can have a go and should get something out of the competition.</p> <p>There are 5 categories with different levels of difficulties:</p> <ul style="list-style-type: none"> • Primary - Class 3rd and 4th (8-10 years old) • Primary – Class 5th and 6th (10-12 years old) • Secondary – 1st and 2nd Year (12-14 years old) • Secondary – 3rd and 4th Year (14-16 years old) • Secondary – 5th and 6th Year (16-18 years old) <p>The problems come in three levels of difficulty: Easy, Medium and Hard. Each level of difficulty consists of 5 questions.</p>
Web link	https://bebras.techweek.ie/#split
References/ online sources	<p>Bebras Community</p> <p>https://www.bebras.org/?q=join_us</p>

	https://www.bebbras.org/?q=goodtask
Additional notes	Students do not have to prepare or practice anything for the Challenge

Best Practice 7	
Topic/ Area	Science, Technology, Engineering, Arts & Maths
Title	Irish Girl Guides Innovatively Engaging with STEM
Type of Best Practice	To inspire and guide the best in STEM education
Date released	June 2018
Partners/ network	Science Foundation Ireland / Irish Girl Guides
Description of the methods/ approach	<p>Part of the remit of Science Foundation Ireland (SFI), through its SFI Discover Programme, is to inspire and guide the best in STEAM education and public engagement.</p> <p>Due to the nature of the organization the sessions will take place in informal settings and focus on younger females aged 7-10 years old.</p>
Purpose/Aim	<p>By encouraging younger girls to explore STEAM activities, it is hoped to encourage them to pursue STEAM subjects in school and to, perhaps, consider pursuing STEAM careers when they leave school.</p> <p>Research has shown that fewer females pursue careers in STEAM industries and that often they have made decisions before mainstream interventions. This approach introduces career potential earlier in a non-competitive environment.</p>
Evaluation (results) of its effectiveness (if applicable)	N/A
Overview of the lessons learned which are relevant to the project	<p>This is 1 of 41 wider initiatives being funded through the SFI Discover programme.</p> <p>It will stimulate important public conversations around scientific research and will highlight the individual, societal and economic value of encouraging more people (young</p>

	<p>females in particular) in Ireland to explore science-related careers, earlier.</p> <p>This is intended to shine a light on Ireland as a hub for excellent research that is far-reaching and inclusive.</p>
Web link	https://www.irishgirlguides.ie/innovatively-engaging-stem/ (2018)
References/ online sources	https://www.irishgirlguides.ie/ladybirds-mark-science-week-by-doing-new-stem-badge/
Additional notes	This and other projects are intended to pave the way for an innovative future.

Best Practice 8	
Topic/ Area	Science, Technology, Engineering, Arts & Maths
Title	DCU - Learn it Academy
Type of Best Practice	Exploration of Science, Technology, Engineering and Maths and other subjects in new, fun and innovative ways that supplement and enhance young people's school education.
Date released	2009
Partners/ network	LEGO® Education, DCU, Learnit
Description of the methods/ approach	<p>The only official partner of LEGO® Education in Ireland there are after-school classes, weekend workshops, summer camps, birthday parties and other events inside schools, colleges, libraries, homes and further education venues throughout the country.</p> <p>Workshops include:</p> <ul style="list-style-type: none"> • Early Builders • Junior Robotics

	<ul style="list-style-type: none"> • Senior Robotics • Girl Power • Family Workshops • Parents Playtime
Purpose/Aim	<p>Through award-winning camps and workshops, young children not only gain a deeper understanding of STEM subjects, they also learn how to think creatively, solve problems and work as a team - all key skills which can be applied to other subjects and brought with them into adulthood.</p> <p>With an increasing demand for our services, we are taking our classes and camps to a growing number of venues throughout Ireland. See our Locations page to find the nearest one to you.</p>
Evaluation (results) of its effectiveness (if applicable)	<p>Since launching in 2009, Learnit as wider organization has delivered an expanding range of professional, hands-on, engaging workshops. 68,488 young people have participated</p> <ul style="list-style-type: none"> • 3482 Workshops taken • 2886 School workshops delivered
Overview of the lessons learned which are relevant to the project	<p>They also provide courses in Ireland's leading teacher training colleges and collaborate with other third level institutions through sister organization - STEM Solutions</p>
Web link	https://www.learnit.ie/
References/ online sources	https://www.learnit.ie/stem-solutions https://www.learnit.ie/lego-education
Additional notes	https://www.learnit.ie/helpful-links - Join their Mailing List

Best Practice 9		
Topic/ Area	Science, Technology, Engineering, Arts & Maths	
Title	STEM Teacher Internship programme	
Type of Best Practice	STEM Teacher Training	
Date released	2015	

Partners/ network	Dublin City University, Accenture, AIB, Alexion, Bank of Ireland, Ericsson, Gas Networks, Ervia - Irish Water, EY, Fidelity International, Fidelity Investment, GE, HPE, IBM, Intel, Microsoft, PWC, SSE Airtricity, Virgin Media, Vodafone, Xilinx.
Description of the methods/ approach	<p>The STEM Teacher Internship programme aims to help young teachers educate future students about career paths in Science, Technology, Engineering & Maths.</p> <p>This is based on research that has found that teachers are key influencers of students' subject choices, second only to parents.</p> <p>Through the internships 'pre-service' or 'newly graduated' STEM teachers will gain hands-on experience of the many careers and opportunities available within STEM industries directly in the companies in the sector.</p>
Purpose/Aim	<p>It is intended that this approach will help them to encourage participation by their own students, particularly female students, in STEM subjects.</p> <p>The programme provides opportunities for DCU 's primary and post-primary concurrent and consecutive teacher education programmes, including BSc Science Education, BSc Physical Education with Biology/Mathematics, B.Ed (Primary), Professional Masters in Education (PME) primary and post-primary.</p>
Evaluation (results) of its effectiveness (if applicable)	<p>"The importance of developing teachers' STEM competences cannot be emphasised enough, especially as teacher quality, not funding, is the determinant factor among conditions that support the performance of the world's best education systems." - Deirdre Butler, Professor, DCU Institute</p> <p>"I think the STEM internship is a huge opportunity for teachers, it gives us the chance to understand the wide variety of careers that subjects like science and maths offer.</p> <p>It has also highlighted to me skills that I can pass on in the classroom which can be of benefit to students who wish to</p>

	<p>pursue these careers.” - Julie Robinson, BSc in Science Education</p> <p>57+ DCU STEM teachers with a 12-week experience in 20 of Ireland’s leading companies.</p>
Overview of the lessons learned which are relevant to the project	The impact of this programme is such that it extends and deepens teachers' competences and knowledge of STEM and enhances the teaching and learning of STEM in their classrooms/schools."
Web link	https://www.dcu.ie/news/news/2019/Apr/STEM-Teacher-Internship-programme-connects-teachers-and-industry-DCU.shtml (2019)
References/ online sources	https://www.dcu.ie/news/2017oct/s1017v.shtml (2018)
Additional notes	<p>Paula Neary, Managing Director and STEM Sponsor, Accenture in Ireland said, “we have been conducting research into girls’ participation in STEM since 2013. Our most recent report highlights the challenges that continue to exist in equipping teachers with the knowledge to inform younger females of the opportunities presented by a STEM career. As Ireland continues to position itself as the epicentre of the world’s digital economy, we need to future proof the talent pipeline, so that half the population isn’t excluded from the opportunities that STEM presents and to this end, industry has an important role to play.”</p>

<p>Best Practice 10</p>	
<p>1. Topic/ Area</p>	<p>STEAM for All, STEAM for Me, STEAM4U Toolkit & Stories</p>
<p>2. Title</p>	<p>STEAM4U - Raising students perceived self-efficacy in STEAM to provide opportunities for all</p>
<p>3. Type of Best Practice</p>	<p> <input type="checkbox"/> PD/ Training Programme <input checked="" type="checkbox"/> Toolkit <input checked="" type="checkbox"/> Online Tools, Applications or Platform <input checked="" type="checkbox"/> Reports <input checked="" type="checkbox"/> Handbook/ Guidelines <input type="checkbox"/> Self-Assessment Test <input type="checkbox"/> Other, please specify </p>
<p>4. Date released</p>	<p>13 Mar 2019 (the Artifact) & 21 Oct 2019 (the Strategies)</p>
<p>5. Partners/ network</p>	<p> 1. Crecim-Universitat Autònoma de Barcelona 2. Carme Grimalt-Álvaro and Digna Couso, CRECIM – Centre for Research in Science and Mathematics Education. </p>
<p>6. Description of the methods/ approach</p>	<p> 1. The belief and intuition that teens’ empowerment and agency need to be tackled directly, as teens are a powerful and the most important actor in the educational scenario. 2. STEM stance is the way a person thinks about STEM-related activities (Science, Technology, Engineer and Mathematics), content, careers... especially expressed in a publicly stated opinion. </p>

7. Purpose/Aim	<p>1. Develop and offer to all stakeholders different tools and guidelines for the promotion of self-efficacy in STEAM.</p> <p>2. Improve existing educational strategies -in current formal and non-formal learning environments- that promote the improvement of self-efficacy in STEAM for all students aged from 10 to 14 years old.</p>
8. Evaluation (results) of its effectiveness	N/A
9. Overview of the lessons learned which are relevant to the project	<p>Self-efficacy beliefs are difficult to modify, but not impossible. The STEAM4U project have undertaken different actions to raise 10-14-year-old teens self-efficacy both in formal and non-formal educational environments, and have identified and grouped several strategies with promising results</p>
10. Web link	<p>https://steam4u.eu</p>
11. References/online sources	<p>1. Artifacts addressed to 10-14-year-old teens https://steam4u.eu/homepage/steam4u-on-line-guide/artifacts-addressed-to-10-14-year-old-teens</p> <p>2. STEAM is for ALL - The role of self-efficacy in STEAM https://steam4u.eu/homepage/steam-is-for-all/</p>
12. Additional notes	<p>According to the project partners, although there is a strong consensus in the field that self-efficacy beliefs can positively act in the stance on STEM of young people, there are few references about how to raise it in 10-14 year-old students.</p>

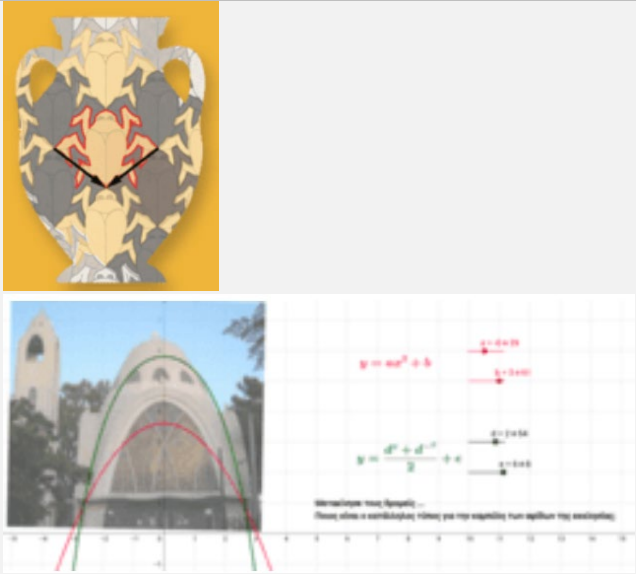
<p>Best Practice 11</p>	
<p>1. Topic/ Area</p>	<p>Friezes, Pavings, Escher, Platonic Solids, Historical Data</p>
<p>2. Title</p>	<p>Math & Art in Athens</p>
<p>3. Type of Best Practice</p>	<p> <input type="checkbox"/> PD/ Training Programme <input type="checkbox"/> Toolkit <input checked="" type="checkbox"/> Online Tools, Applications or Platform <input type="checkbox"/> Reports <input checked="" type="checkbox"/> Handbook/ Guidelines <input type="checkbox"/> Self-Assessment Test <input type="checkbox"/> Other, please specify </p>



4. Date released	2017-18
5. Partners/ network	Doukas School teachers and students (ages 14-16)
6. Description of the methods/ approach	Students and teachers of Doukas School visited museums, churches and monuments in the city of Athens. They focused on details of sculpture, table, mosaic and decorative elements and observed the paving in the building, the temple, the stained glass windows, the draft railings. They discussed about the way all the above were developed and combined by the artists and the architects;
7. Purpose/Aim	Design of a unique application using Google maps and Geogebra, to present areas with specific artwork. In this way we are able to show the mathematical background of the analysis, reproduction - application, similar works – exhibits and further historical data about the art and the artist.
8. Evaluation (results) of its effectiveness	N/A
9. Overview of the lessons learned which are relevant to the project	During the implementation of the project, students recognized specific mathematical objects behind all of these structures, they explored their properties they study the way in which famous mathematicians dealt with all these objects in the past, they reproduce them using the appropriate software (GeoGebra) and they presented their results and conclusions
10. Web link	https://www.geogebra.org/m/NvUk8RTC
11. References/online sources	Greek Version: https://www.geogebra.org/m/Rjepeevs
12. Additional notes	As the project involved students from different classes, four groups of students were formed that dealt with: <ul style="list-style-type: none"> - Belt symmetries - friezes, - Paving with the use of regular polygons, - Paving techniques through Escher's work,

- Platonic solids - symmetry in space.

Best Practice 12	
1. Topic/ Area	Communication of Science to youth in a gender inclusive way
2. Title	Ypatia – Expect Everything
3. Type of Best Practice	<input type="checkbox"/> PD/ Training Programme <input checked="" type="checkbox"/> Toolkit <input type="checkbox"/> Online Tools, Applications or Platform <input type="checkbox"/> Reports

	<input type="checkbox"/> Handbook/ Guidelines <input type="checkbox"/> Self-Assessment Test <input type="checkbox"/> Other, please specify
4. Date released	2018
5. Partners/ network	Hubs, led by 5 science centres and museums, are located in 14 European countries
6. Description of the methods/ approach	Hypatia offers an accessible, practical and ready-to-use digital collection of activities (modules) for teachers, informal learning organizations, researchers and industry. The modules focus on gender-inclusive ways of educating and communicating STEM, empowers teenagers and explores the range of skills that are needed for a great variety of STEM studies and careers open to young people. The modules are developed by science centres and tested by teenagers and colleagues in other countries. In this way they are applicable internationally.
7. Purpose/Aim	Hypatia is an EU Horizon 2020 funded project that aims to develop a theoretical framework on gender inclusive STEM education and to produce, test and promote a Toolkit with practical solutions and modules The Toolkit is a of 19 activities aimed at teenagers. Each module is composed of guidelines specific for each activity, guidelines dedicated to the theme of gender inclusion and guidance for facilitators on how to on how to manage the group dynamics by implementing different facilitation strategies.
8. Evaluation (results) of its effectiveness	N/A
9. Overview of the lessons learned which are relevant to the project	A key element for good facilitation is the active involvement of the participants every time a concept or content is presented. Involvement means for example: considering participants' personal experience, building on their own point of view or prior knowledge, embedding continuously the contributions of the participants in the process.

	Facilitation takes practice, time and reflection! In order to transfer these concepts into practical situations - and thus to foster engagement, interaction and discussion there is a brief list of suggestions.
10. Web link	http://www.expecteverything.eu/hypatia http://www.expecteverything.eu/hypatia/toolkit/

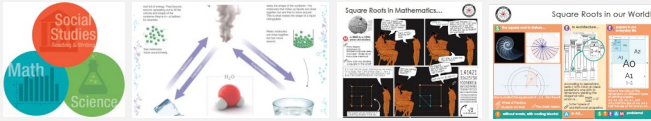
Best Practice 13	  
1. Topic/ Area	Science-Technology-Engineering-Arts-Maths & Social Studies
2. Title	Collections of Educational Infographics (2 independent collections: CollectEdNY & E-I-STEAM)
3. Type of Best Practice	<input type="checkbox"/> PD/ Training Programme <input checked="" type="checkbox"/> Toolkit <input checked="" type="checkbox"/> Online Tools, Applications or Platform <input type="checkbox"/> Reports <input type="checkbox"/> Handbook/ Guidelines <input type="checkbox"/> Self-Assessment Test <input type="checkbox"/> Other, please specify
4. Date released	2017-2020
5. Partners/ network	1: NYS Teacher Leaders of CollectEdNY 2: Partners for the Educational Infographics for STEAM
6. Description of the methods/ approach	1: The Teacher Toolkit of the CollectEdNY provides background knowledge for teachers on what infographics are and why it makes sense to use them. There are explicit connections to the Next Generation Science Standards and the Common Core State Standards in the toolkit. 2: The Educational for Infographics STEAM project (E-I-STEAM) develops visual materials that will help students understand the challenging topics in their books.
7. Purpose/Aim	1: CollectEdNY has developed the Classroom Teacher Toolkit that employs infographics as a way “for students to practice key science literacy skills”. While the focus of these

	<p>lessons is science, this toolkit can be used as a how-to guide on infographics in any content area.</p> <p>2: E-I-STEAM aims:</p> <ul style="list-style-type: none"> - to create teaching methods through innovative approaches; - to engage students in STEAM activities; - to increase the level of knowledge in the key-competences; - to provide hands-on learning opportunities; - to promote internationalization and European values;
8. Evaluation (results) of its effectiveness	There is list generated by experts of the California Academy of Sciences about what makes a good infographic.
9. Overview of the lessons learned which are relevant to the project	<p>When students interpret infographics, they practice reading and understanding graphs, charts, diagrams, and maps; finding patterns in data and interpreting their meaning; and arguing from evidence to support their interpretation of the infographic.</p> <p>When students critique others' infographics, they practice using evidence to support an argument.</p> <p>When students create their own infographics, they gain experience analyzing data, finding and explaining patterns in data, and thoughtfully deciding how to visually present that data.</p>
10. Web link	<p>CollectEdNY: https://www.collectedny.org/frameworkposts/collection-of-infographics</p> <p>E-I-STEAM: https://steam-edu.eu</p>
11. References/ online sources	<p>CUNY HSE Curriculum Framework: http://www.collectedny.org/2016/03/hseframework</p> <p>Infographics in the Classroom Teacher Toolkit:</p>

	<p>https://www.calacademy.org/educators/infographics-in-the-classroom-teacher-toolkit Unpublished Infographic for the E-I-STEAM project:</p> <p>https://www.dropbox.com/s/9lxer36acy0yyqd/Square-Roots-A3.pdf</p>
--	--

Best Practice 14	
1. Topic/ Area	DIY science, citizen science for kids
2. Title	Smart Kids Lab
3. Type of Best Practice	<ul style="list-style-type: none"> • PD/ Training Programme • Toolkit • Online Tools, Applications or Platform • Reports • Handbook/ Guidelines • Self-Assessment Test • Other, Community Art Project
4. Date released	2018
5. Partners/ network	<p>[List of the partners involved, if applicable]</p> <p>Waag Society, Cinekid, RIVM, the Netherlands</p>
6. Description of the methods/ approach	How clean is the air you breathe? Is swimming water the same as drinking water? How many microbes live in the soil beneath your feet? And what does it all mean? HOW

	DOES IT WORK? Choose your topic MAKE YOUR METER and get going in your own neighbourhood.
7. Purpose/Aim	With Smart Kids Lab children can explore water, sound, air, earth and light with homemade measuring instruments. It enables children to map out and interpret their immediate environment at home and at school by means of experiments with the homemade sensors. In this way they playfully come into contact with the possibilities of technology and science.
8. Evaluation (results) of its effectiveness (if applicable)	N/A
9. Overview of the lessons learned which are relevant to the project	N/A
10. Web link	http://smarkidslab.nl/english
11. References/ online sources	Smart Kids Lab has been developed in collaboration with Cinekid and RIVM and has been realized with contributions from the Foundation for Culture and Education and the Horizon 2020 research and innovation programme of the EU. The project is part of a European programme: MAKING SENSE .

Best Practice 15	
1. Topic/ Area	Science
2. Title	ROOTS: Ik ben Science A community-based, multilingual STEAM program
3. Type of Best Practice	<ul style="list-style-type: none"> • PD/Training programme • Toolkit

	<ul style="list-style-type: none"> • Online Tools, Applications or Platform • Reports • Handbook/ Guidelines • Self-Assessment Test • Other, please specify
4. Date released	8 Feb - 20 June 2020
5. Partners/ network	<p>[List of the partners involved, if applicable]</p> <p>a) Name of the partner b) Country of origin c) Role in the practice</p> <p>a) Institute of Science Education and Communication at the Faculty of Science and Engineering, University of Groningen</p> <p>b) The Netherlands</p> <p>c) Organiser</p>
6. Description of the methods/ approach	<p>ROOTS is an after-school community program which offers a space where families, educators, visiting scientists and artists come to work together on science investigations. It offers the residents of Beijum and neighbouring districts opportunities to engage in science-related activities on Saturday mornings.</p> <p>ROOTS is used to refer to the urgency of communities moving towards a more environmentally sustainable future. "Ik ben Science" is used to refer to the programme's aspiration to increase students' self-identification with science, or put simply, seeing themselves as science persons. The activities are not only related to science but incorporate technology, engineering, environmental sciences, the arts and mathematics. The programme aims to offer a space where families, educators, visiting scientists and artists come to work together on science investigations. We envision that a diverse group of persons will find the space welcoming and embrace the practice of science as something within their reach and abilities.</p>

<p>7. Purpose/Aim</p>	<p>The program aims to engage young children living in underprivileged and ethnically diverse communities in science investigations rooted within problems situated in their local contexts, e.g. explorations of the environmental and social implications of earthquakes. It aims for these children to gain an interest in science and consider careers in science, while at the same time helping migrant children and their families connect with their local communities.</p>
<p>8. Evaluation (results) of its effectiveness (if applicable)</p>	<p>The program is still ongoing, so no evaluation yet. However, the Open Day on Feb. 8 th was the first of the 20-week programme that is open to 8-13 year olds</p> <p>On the first day, we had about 50 people packed into the Grand Theatre room of the Trefpunt centre, engaging with attractions such as the blender bikes where you ride the bicycles to make your own smoothie and kitchen science with slime. The feedback has been wonderful with the kids inviting their friends to join them in following sessions.</p>
<p>9. Overview of the lessons learned which are relevant to the project</p>	<ol style="list-style-type: none"> 1. Professional development of the trainers is important in order to support them in developing a shared understanding of STEAM as a set of integrated activities across the different disciplines instead of compartmentalized activities situated in distinct activities. 2. The arts and especially the role of creativity across the STEM fields needs to be addressed explicitly. While ARTS is easy to incorporate in lessons its relevance and value is not directly recognized by the participants.
<p>10. Web link</p>	<p>http://www.rootsikbenscience.com/</p> <p>https://www.rug.nl/sciencelinx/maatschappij/roots_-i-am-science</p>

11. References/ online sources

- 6 shorts videos demonstrating experiments
- 12 Videos and more than 300 images of parents and children engaging in investigations
- Student work (photovoice, drawings etc.)

Best Practice 16



1. Topic/ Area

Science/neurobiology

2. Title

Community Art project with crafted neurons at science festival, organised by Science LinX/University of Groningen

3. Type of Best Practice

- PD/ Training Programme
- Toolkit
- Online Tools, Applications or Platform

	<ul style="list-style-type: none"> • Reports • Handbook/ Guidelines • Self-Assessment Test • Other, Community Art Project
4. Date released	April 2019 - 8th of June 2019 (Science Festival)
5. Partners/ network	<p>[List of the partners involved, if applicable]</p> <p>University of Groningen, Netherlands, organiser science festival Night of Art and Science, together with local partners</p> <p>Neural Knitworks; Australia; providing pattern book and support/advice (see 11 below)</p> <p>Yarn shop 'Achterpand'; Netherlands; providing materials, network of crafters, get-togethers</p> <p>Neurobiologist University of Groningen; Netherlands; providing content to the workshops</p>
6. Description of the methods/ approach	<p>In June 2019, the science festival Night of Art and Science took place in the city of Groningen, The Netherlands, with the theme 'Inclusion'. Giving this theme, our aim was to involve the public in making a Community Art project, showcasing the result during the science festival.</p> <p>Neurobiologists at our faculty of Science and Engineering came up with the Neural Knitwork (see online source below) as a project.</p> <p><u>Planning project</u> with a team of neurobiologists and science communicators (aim, timeline, events) + patterns provided by Neural Knitworks</p> <p><u>PR</u> (social media, flyers, website of science festival, interview with local newspaper) to announce the Community Art Project.</p> <p><u>Organise events:</u></p> <ul style="list-style-type: none"> - get-togethers at yarn shop to craft neurons - lessons at schools by neuron biologist explaining use of neurons and crafting them

	<ul style="list-style-type: none"> - stand at craft market with flyers and materials to get the community involved <p><u>Science festival:</u> We managed to get 270 neurons (our aim was 200). Selected on color, we hang them in a tree shaped structure at a prominent place at the festival. Neurobiologists were present to inform the public about the use of neurons, and the project.</p>
7. Purpose/Aim	<p>The aim was:</p> <ol style="list-style-type: none"> 1) to get groups of the public involved that normally would not participate in science 2) to teach the public about what neurons are and how important they are for our functioning, while crafting them.
8. Evaluation (results) of its effectiveness (if applicable)	N/A
9. Overview of the lessons learned which are relevant to the project	<ul style="list-style-type: none"> - it's a great way to get young and old people involved that normally would not participate that easily in science - Good to include a yarn shop as partner in the project, facilitating get-togethers, providing materials and using their network. - The patterns of neurons had different levels, from very easy (winding) to more difficult (knitting or crochet), so both inexperienced and very experienced people could contribute and make a neuron to their personal liking - It's a nice method to get school children involved in science. They learn about the function of neurons, while crafting them. They are really proud of their work and wanted to share the

	<p>results with others. We organised a special event during the daytime (as the festival started in the evening) for children to come and have a look at their neurons in the art work. They were really enthusiastic about seeing their own neuron. After the science festival, all neurons return to the children who made them.</p> <ul style="list-style-type: none"> - Two months was relatively short for organising such a community art project.
10. Web link	
11. References/ online sources	<p><i>Neural knitworks:</i> https://www.scienceweek.net.au/neural-knitworks/</p> <p><i>* If you wish to host a Neural Knitwork event outside of Australia's National Science Week or the Cambridge Science Festival we ask that you make contact to seek permission to use the material.</i></p> <p>https://nachtvankunstenwetenschap.nl/acts/community-art-neural-knitworks/</p>

Best Practice 17	
1. Topic/ Area	Arts
2. Title	Google Arts and Culture: Experience culture in 360°
3. Type of Best Practice	Online Tools, Applications or Platform
4. Date released	N/A
5. Partners/ network	Google
6. Description of the methods/ approach	<p>The teacher can support his or her theoretical classes with a series of 360° resources, creating an immersive experience and the possibility of seeing the concepts analysed in the theoretical class from the inside. The students can also use these resources in a particular way, increasing their motivation and interest in the topics covered in these resources.</p>
7. Purpose/Aim	<p>To bring cultural spaces, performances or places that generally cannot be visited closer to the public of all ages in an interactive way</p>
8. Evaluation (results) of its effectiveness (if applicable)	N/A
9. Overview of the lessons learned which are relevant to the project	<p>Experience culture at 360°, not only art galleries but also architectural jewels, cultural centers and other spaces such as a space shuttle or fashion shows</p>
10. Web link	https://artsandculture.google.com/project/360-videos
11. References/ online sources	<p>Opéra National de Paris: https://g.co/arts/f2h8jDh669ZzuR6g9</p> <p>Bruegel, A Fall with the Rebel Angels: https://g.co/arts/ZeAjeqc89j6wj3NY6</p>

British Fashion Icons in 360°:

<https://g.co/arts/gUDdv7FAvLn8sQ118>

Best Practice 18	
1.Topic/ Area	HTML language
2.Title	Codecademy
3.Type of Best Practice	Online Tools, Applications or Platform
4.Date released	N/A
5.Partners/ network	N/A
6.Description of the methods/ approach	The resources and different online courses contained in the webpage could be used in the Flipped Classroom methodology. Students will watch the different videos and complete the different courses at home before working on more specific aspects related to them in the classroom.
7.Purpose/Aim	The purpose of the use of these elements is the acquisition of knowledge related to the creation of websites using HTML language.
8.Evaluation (results) of its effectiveness (if applicable)	This acquisition of knowledge could be evaluated through a list of compulsory elements that should appear in the website created by the students.
9.Overview of the lessons learned which are relevant to the project	The different lessons will consist on the creation of a webpage. By working in groups, students will be able to put the knowledge acquired before into practice.
10.Web link	https://www.codecademy.com/learn/learn-html
11.References/ online sources	https://www.codecademy.com/learn/learn-html

Best Practice 19	
1.Topic/ Area	Programming
2.Title	Scratch
3.Type of Best Practice	Online Tools, Applications or Platform
4. Date released	N/A
5. Partners/ network	N/A
6. Description of the methods/ approach	The teacher will explain the students the theory about programming by using the resource in class with them, showing students how to use the different commands. Once they learn the basic contents of programming, students will have to face different templates so they will progressively acquire greater abilities in this area.
7. Purpose/Aim	Students will learn how to basically program using Scratch, an online easy-to-use tool for that purpose.
8. Evaluation (results) of its effectiveness (if applicable)	Students will work on different templates that will follow a difficulty path, so the first one will be the easiest and the last one the most difficult one. This way, evaluation will be simultaneous as students will have to start a new template once they finished the previous one.
9. Overview of the lessons learned which are relevant to the project	These resources and videos will enable students acquire a basic knowledge of programming using Scratch.
10. Web link	https://scratch.mit.edu/projects/editor/?tutorial=getStarted

Best Practice 20	
1.Topic/ Area	Programming
2.Title	Create your own videogame using Scratch
3.Type of Best Practice	Online Tools, Applications or Platform
4.Date released	N/A
5.Partners/ network	N/A
6.Description of the methods/ approach	Flipped classroom can be used in order to let students acquire the different contents following their own pace. Students will watch the different videos outside school and work on their videogames in class. If needed, teachers will provide different explanations using digital blackboards and projectors.
7.Purpose/Aim	Students will learn how to program and acquire basic contents of programming in order to create their own videogame.
8.Evaluation (results) of its effectiveness (if applicable)	Teachers could give simultaneous feedback to students in order to improve their videogames and correct different mistakes. Moreover, we could give students the chance to try their classmates' videogames and provide peer feedback.
9.Overview of the lessons learned which are relevant to the project	These resources and videos will enable students acquire a wide knowledge of programming using Scratch.
10.Web link	https://scratch.mit.edu/
11.References/ online sources	https://www.youtube.com/watch?v=PfQiTBbHHY4 https://www.youtube.com/watch?v=IkzUx_VTnLg https://www.youtube.com/watch?v=6bopWxYR0g4

<https://www.youtube.com/watch?v=Hqm2fE41Ci8>

<p>Best Practice 21</p>	
<p>Topic</p>	<p>Resources for Teachers of all STEAM subjects across all Primary & Secondary age groups - Website and compendium of teaching resources</p>
<p>Title</p>	<p>TES</p>
<p>Duration</p>	<p>N/A</p>
<p>Lead Partner</p>	<p>N/A</p>
<p>Partners/ network</p>	<p>N/A</p>
<p>Web link</p>	<p>https://www.tes.com/</p>
<p>Relevant documents or outputs</p>	<p>https://www.tes.com/teaching-resources/steam</p> <p>https://www.tes.com/teaching-resources/blog/scientific-explorations-eyfs - a selection of ideas and resources aimed at early years learners</p> <p>https://www.tes.com/teaching-resources/blog/inspirational-steam-ideas-primary - a selection of ideas and resources aimed at the primary level students</p> <p>https://www.tes.com/teaching-resources/blog/popular-steam-projects-secondary - a selection of ideas and resources aimed at secondary level students</p>
<p>Description</p>	<p>Tes is a global educational organisation working with 25,000 schools in over 100 countries. They provide recruitment support for schools and information, advice and guidance to teachers and school leaders. They provide access to a wide range of teacher made resources across all national curricular subjects</p>

Methodology	Teacher made resources available via website and printable documents. The majority of the resources are OERs, but some require a subscription to access or a small one off charge
Output Benefits	Thousands of OERs for teachers of primary and secondary level. Professional development and peer support opportunities
RISKS	N/A
Workable - Transferable practices	https://www.tes.com/teaching-resources/blog/putting-a-steam-lessons
References	N/A
Additional notes	N/A

Best Practice 22		
Topic	Resources for Teachers of all STEAM subjects across all Primary & Secondary age groups - Website and compendium of teaching resources	
Title	STEM Learning	
Duration	N/A	
Lead Partner	N/A	
Partners/ network	N/A	
Web link	https://www.stem.org.uk	
Relevant documents or outputs	https://www.stem.org.uk/resources https://www.stem.org.uk/resources/curated-collections/primary-0 - primary level resources https://www.stem.org.uk/resources/curated-collections/secondary-and-level-design-and-technology-0 - secondary level DT resources https://www.stem.org.uk/resources/curated-collections/secondary-and-level-mathematics-0 - secondary level Math resources	

	<p>https://www.stem.org.uk/resources/curated-collections/secondary-and-level-science-0 - secondary level Science resources</p> <p>https://www.stem.org.uk/resources/curated-collections/secondary-and-level-computing-0 - secondary level Computing resources</p>
Description	STEM Learning is the largest provider of education and careers support in science, technology, engineering and mathematics (STEM) within the UK. They are supported by a unique partnership of Government, charitable trusts and employers, and are dedicated to raising young people's engagement and achievement in STEM subjects and careers
Methodology	Online community of teachers and educators providing OERs. Teacher created resources that are free-to-access and quality assured. Opportunity to share your own resources for other to access
Output Benefits	Thousands of OERs for teachers of primary and secondary level. Professional development and peer support opportunities
RISKS	N/A
Workable – Transferable practices	<p>https://www.stem.org.uk/stem-clubs</p> <p>https://www.stem.org.uk/enrichment</p> <p>https://www.stem.org.uk/resources/curated-collections/using-space-context-0</p>
References	N/A
Additional notes	N/A

Best Practice 23		
Topic	Information, advice and guidance for educators	
Title	Resilient Educator	
Duration	N/A	
Lead Partner	N/A	
Partners/ network	N/A	
Web link	https://resilienteducator.com/	
Relevant documents or outputs	<p>https://resilienteducator.com/collections/steam-teaching-resources/</p> <ul style="list-style-type: none"> - tips, support and resources for the STEAM subjects including practical activities and classroom based projects <p>https://resilienteducator.com/collections/math-teaching/</p> <ul style="list-style-type: none"> - tips, support and resources for Math covering all educational levels 	
Description	Resilient Educator is a website to support the personal and professional development of educators. It provides a range of information, advice and guidance to teachers including classroom resources and toolkits.	
Methodology	Online compendium of resources and sign-posting	

Output Benefits	Personal and professional support for educators
RISKS	N/A
Workable – Transferable practices	https://resilienteducator.com/collections/integrating-technology-in-classrooms/ https://resilienteducator.com/collections/downloadables/

Best Practice 24	
Topic	Coding and programming
Title	BBC micro:bit Educational Foundation
Duration	N/A
Lead Partner	N/A
Partners/ network	ARM, BBC, British Council, The Institution of Engineering and Technology, Lancaster University, Microsoft and NOMINET
Web link	https://microbit.org/
Relevant documents or outputs	https://microbit.org/get-started/first-steps/set-up/ - how to set up a micro:bit device https://microbit.org/get-started/user-guide/overview/ - user guide to the features and specifications of the micro:bit

	<p>https://microbit.org/get-started/bbc-microbit-in-school/ - how to best utilise the micro:bit in the classroom</p> <p>https://microbit.org/get-started/home-learning/ - easy-to-follow activities for students to conduct at home</p> <p>https://microbit.org/lessons/ - free-to-use lesson plans that utilise the micro:bit computers as part of a structured activities</p>
Description	BBC micro:bit Educational Foundation is a UK based not for profit organisation aimed at inspiring children to participate in the digital world. The micro:bit itself is a tiny computer that makes coding tangible and promotes digital creativity.
Methodology	The organisation provides the micro:bit computers to schools or individuals and the website provides support and guidance for using them as a teaching/learning resource
Output Benefits	Hands-on practical resource to help students learn coding and programming skills
RISKS	N/A
Workable – Transferable practices	<p>https://microbit.org/projects/</p> <p>https://microbit.org/code/</p>

Best Practice 25	
1.Topic/ Area	Science
2.Title	Science For Fun
3.Type of Best Practice	EU Project
4.Date released	2018
5.Partners/ network	<ol style="list-style-type: none"> 1. Pro Work - The Netherlands 2. Universidad Autónoma de Madrid – Spain 3. University of Humanities and Economics in Lodz – Poland 4. Fundación Siglo22 – Spain 5. JKVG vzw – Belgium

	<p>6. Sociedade Portuguesa de Inovacao – Portugal</p> <p>7. Natsionalen ucheben tsentar – Bulgaria</p> <p>8. Ljudska univerza Velenje – Slovenia</p> <p>9. Euroface Consultign s.r.o. - Czech Repulic</p>
6. Description of the methods/ approach	In Service of e-training programs for Science Teachers. The project developed an online learning environment for science teachers with tools and learning modules.
7. Purpose/Aim	The subject of the project is to create an attractive and effective way of teaching science by an innovative model. One of the aims of the project is also to assess the evolution of science learning through the course of the project and explore the possibilities of big data analysis to help develop interesting and methodological innovative scientific curricula.
8. Evaluation (results) of its effectiveness (if applicable)	As a result of the project, a series of modules have been developed that can be used by teachers in their classes, in different languages and adapted to different European countries. Once the project is finished, the partners will evaluate the impact and results of the project.
9. Overview of the lessons learned which are relevant to the project	Any of the modules developed by the Science4Fun project is relevant to this project.
10. Web link	https://www.science4fun.eu/



Overview of the Lesson Plans (Learning activities)

Various Interdisciplinary learning activities have been produced by the consortium across 6 EU countries (Cyprus, Greece, Ireland, Netherlands, Spain, UK) which are

60



embedded within a total of 12 Lesson plans of 2 teaching periods each. These can be freely used and adjusted to the needs of each course to promote STEAM education practices across EU.

Cyprus

Lesson Plan 1

Course: Mathematics	
Lesson 2: Coding and Programming	
Area: Programming, Technology, Mathematics	
Number of students: 22 (2 classes with 11 students each)	
Date :13/10/2020 and 20/10/2020	
Grade Level: 6	Timeframe: 80 minutes
<p>Lesson Overview (Please edit accordingly):</p> <ul style="list-style-type: none"> In this course students are introduced to the concept of coding and programming, using programming software by programming the Robot Pro - Bot. 	
<p>Objectives</p> <p>At the end of the course students must be able to:</p> <ul style="list-style-type: none"> Understand the concepts of programming and algorithms through specific examples. Program the robot Pro - Bot to solve various problems. Use various programming software to solve different educational missions-scenarios. 	
<p>Material/ resources</p> <ul style="list-style-type: none"> 3 computers 2 Robots Pro - Bot 5 Tablet A.L.E.X. - free app Large cardboard (A1) 	

Activities

1. **Introduction (10 minutes)**

Children are introduced to basic knowledge of control systems, algorithm and programming/coding, through different examples. Introduction to robots and the areas used.

2. **Presentation and engagement with stations (60 minutes)**

The teacher presents the three stations with which the students will work.

STATION 1: Students will work with Pro-Bot to schedule it to perform various missions on the activity mat.

STATION 2: Students will work on A.L.E.X. programming software to fulfill missions. In the end, they design and plan their own educational mission.

STATION 3: Students work on the computer through [the www.code.org](http://www.code.org) website, in order to program their hero to pass all stages.

Note: Due to the health pandemic protocols there will be no rotation of stations.

3. **Repeat - Completion of the course (10 minutes)**

Each student presents his work to the others. Geometric patterns can be exposed in the school lobby.

Rating (5 minutes)

Students are asked to fill out an online form in order to evaluate, reflect and self-assess their understandings and skills on the subject matter (available in Greek ONLY).

<https://forms.office.com/Pages/ResponsePage.aspx?id=z-jb7DjOmkS2fbqA5mVJGkiaFcr7yaROoqDpunL4nziURVZSWkRBQVc2NIhWQVZVSFUxTTM4RUo2Qi4u>

Instructions for teachers

Through this course students are invited to code through the use of various programming software, ground robots and the code.org website. The activities require design skills, decision-making and cultivation of computational thinking through problem-solving. The teacher support and guides students through mentoring, as a medium to encourage students to work constructively and remain focus for the accomplishment of their goal.

Lesson Plan 2

Course: Mathematics	
Lesson 1: Geometry (Stereometry) – Relationships between edges, vertices and peaks	
Area: Mathematics, Technology	
Number of students: 21 (10 & 11)	
Date: 12/10/2020 and 19/12/20	
Grade Level: 6	Timeframe: 80 minutes

Lesson Overview:

- In this course students explore three-dimensional shapes, learning their names, characteristics and exploring through illustration the relationship between edges, faces and vertices.

Objectives

At the end of the course students must be able to:

- Name, describe and classify three-dimensional shapes (cube, pyramid, rectangular parallelogram, sphere, cylinder, cone) using mathematical terminology (edges, faces, vertices) and associate them with relevant objects of the environment.
- Recognize and construct cube spreads, rectangular parallels, prisms and pyramids, using various means and software.

Material/ resources

- 5 sets of geometric solids
- Educational video: <https://www.youtube.com/watch?v=t7-XsrSBllc>
- Website link: <https://illuminations.nctm.org/Activity.aspx?id=3521>
- Website link: <https://www.learner.org/wp-content/interactive/geometry/eulers-theorem/>

Activities

1. **Dash - Initial Reflection (7 minutes)**

The following scenario is presented to children: They should teach children of younger ages the three-dimensional shapes, a concept that, in order to be understood, needs children to have hands-on experience and experiment with the material. Due to the lack of educational materials in school, the students have to co-create their own artefacts. The teacher, therefore, asks the students to study the geometric solids, which will be the subject of their lesson.

2. **Reflection on previous knowledge (8 minutes)**

Students use various geometric solids and they try to group them according to their characteristics (prisms, pyramids, cylinders, cones, sphere). Then, they write their names on stickers.

3. Exploration of geometric solids and discovery of the relationship between the edges, faces, and vertices (40 minutes).

Students enter the <https://www.learner.org/wp-content/interactive/geometry/eulers-theorem/> website and explore the spreads, edges, faces and vertices of geometric solids. Then, they complete Worksheet 1.

4. Construction of geometric solids using materials (15 minutes)

Students construct geometric solids using different geometric shapes. They choose the appropriate shapes (triangles, squares, etc.) to construct the geometric solids requested and complete Worksheet 2.

5. Revision (5 minutes)

Through the use of a relevant software, the teacher revives the knowledge acquired by the students during the teaching course and provides Euler's Theorem. Suggested application via <https://www.learner.org/wp-content/interactive/geometry/eulers-theorem/ed.>

6. Assessment (5 minutes)

Students are evaluated through a short test using Quizlet, where the teacher can easily and quickly get the results and see whether the course objectives have been achieved

<https://quizizz.com/join?gc=28788642>

Instructions for teachers

The geometry course is one of the most difficult to understand topic of mathematics and makes it difficult for students to comprehend the elements of geometric solids. This is why through this course students will have the opportunity to interact with geometric solids in various ways: Through experimentation with real solids, the use of technology and construction using different materials.

In this way, the students will have the opportunity to explore geometric solids, discovering their capabilities and developing a greater understanding of 3D geometry. Thus, the course will meet the needs of all students, but at the same time will enhance the interest and motivation of the students. The teacher will support and guide the students, providing adequate feedback when needed.

Greece

Lesson Plan 3

Course: **STEAM**

Lesson: **Spread of Virus and Face Masks Creation**

Area: **Science, Technology and Art**

Grade Level: **8-9** (ages 13-15)

Timeframe: **90 min** (2 didactic hours)

Lesson Overview:

Six activities for two didactic period of 90 min include how germs and viruses are spreading, how we can measure virus contagious, and how we can stop them from spreading. One of our practices to stop germs from spreading is to use a face mask. So, in this lesson plan we give guidelines on how to design and create face masks for each student using unused and cheap materials.

Objectives:

Upon completion of this Lesson students will be able to:

- Describe how germs and viruses are spreading
- Explain how to stop viruses from spreading
- Measure the virus contagious according to "r0" (mathematical problem)
- Identify the technology and the materials used for face masks
- Design a personal artistic shape of a face mask
- Create a simple face mask for protection (hands-on activity)

Material - Resources:

- Interactive boarding application (optional): e.g. padlet, lino etc
- How do germs spread (Infographic): <https://visual.ly/community/Infographics/health/how-do-germs-spread>
- How can we stop virus from spreading?
- How do air filters work? (YouTube video): <https://www.youtube.com/watch?v=WhiTIkZlwl4>
- How coronavirus spreads through a population and how we can beat it (Simulation): <https://www.theguardian.com/world/datablog/ng-interactive/2020/apr/22/see-how-coronavirus-can-spread-through-a-population-and-how-countries-flatten-the-curve>
- CDC on Homemade Cloth Face Coverings (Instructions): <https://www.cdc.gov/coronavirus/2019-ncov/prevent-getting-sick/how-to-make-cloth-face-covering.html>
- How to make your own face mask
- Face mask differences (Project: Protect Instructions): <https://projectprotect.health/#/>
- WHO - Coronavirus disease pandemic (Info): <https://www.who.int/emergencies/diseases/novel-coronavirus-2019>
- Material: Old t-shirts, pens-markers, scissors, rubber bands, strings (for the mask creation)
- Free Resources and Lessons for COVID-19 <https://ngl.cengage.com/assets/html/covid19>

Lesson Activities:

The plan can be completed in two didactic hours, the first one with 3 activities related to the germs - virus spreading and the second with also 3 activities related to the technology - materials of a face mask and its design - creation.

1. Brainstorming on how germs and viruses are spreading (15')

The teacher explains the differences between germs and virus and starts a small brainstorming session with the students that share their ideas and them dividing them into categories, about how germs and viruses spread (e.g. touching, eating, drinking, breathing, bites).

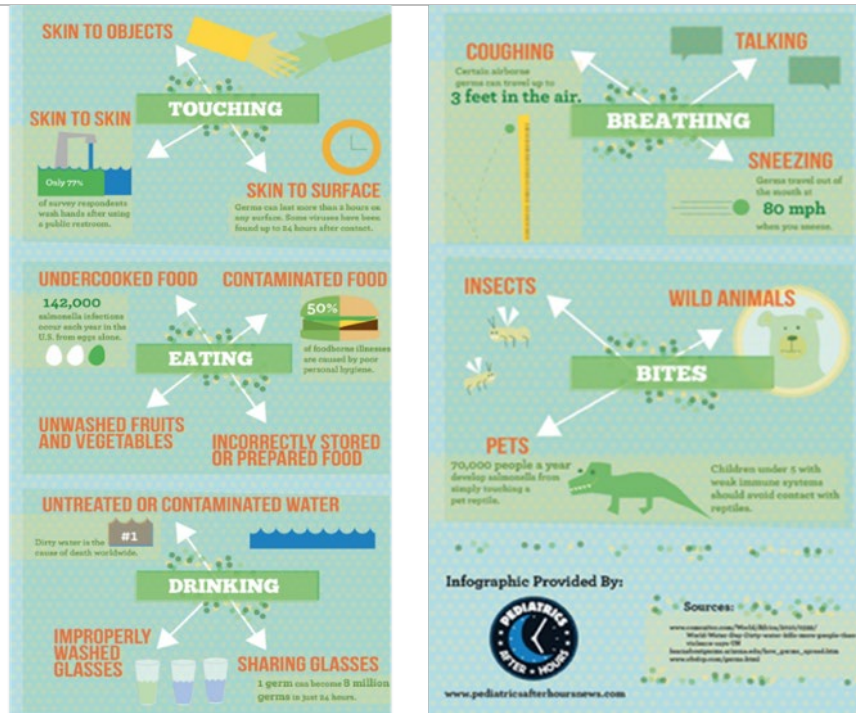

After the discussion s/he presents the *proposed infographic*, comparing their findings with the facts of the infographic. S/he can also distinguish the spreading of covid-19 through contact and in the air, and not by pets and insects. They also discuss, as a short reminder on how we can *stop covid-19 from spreading*.



2. Simulation and measurement of how coronavirus spreads through a population (25')

During this activity students form small groups and try to measure how contagious virus can be. Students, with their teacher's help, measure the most usual basic

reproduction number (r_0 as an integer to make this simpler), which indicates how many new cases one infected person generates.

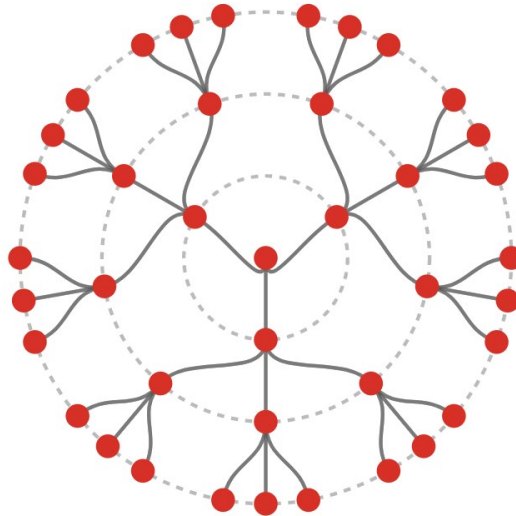

Students will be asked to find a mathematical expression for calculating the infected person according to the r_0 parameter and the number of phases (in the figure $r_0=3$, phases=3 and 39 people infected by the 1st in the center).

3. Our means to stop germs from spreading (5')

A small closing discussion about what and why do we use in order to stop germs from spreading (soap, alcohol-based solutions, bleach, face masks) and what we don't use! Students can also watch the following YouTube video: "How do air filters work?":

<https://www.youtube.com/watch?v=WhiTIkZlwI4>

4. Technology and the materials for face masks (5')

The teacher presents 2-3 slides that aim to excite students' imagination on how many types of masks there are, what materials they are made of, and the different uses.

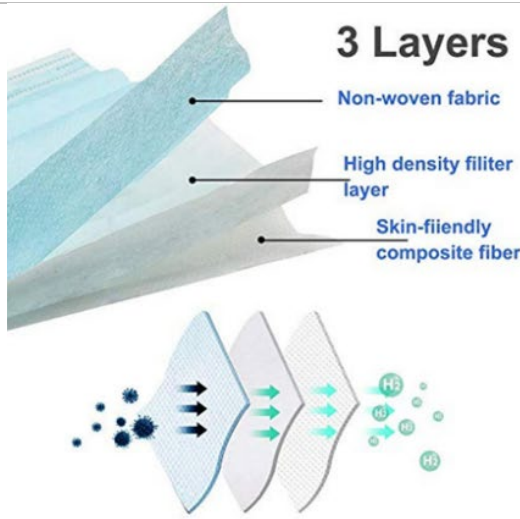

Face Mask Differences

ProjectProtect

In partnership with Intermountain Healthcare, University of Utah Health and Latter-day Saint Charities

Type	Protection	Appropriate for	Use Guidelines	Reuse	Fabrication
<p>Homemade Cloth Mask</p>	May protect the wearer and those around them from large droplets coming from coughs or sneezes	For community members following use guidelines	Wearers should practice physical distancing, handwashing, and avoid touching their faces	Can be reused when properly cleaned.*	Can be easily made at home using breathable materials such as cotton or cotton blend
<p>Clinical Mask</p>	Resistant to fluids and will filter small particles	For frontline health workers	Health workers should follow institutional protocol	Health workers should follow institutional protocol	Must be made using medical-grade polypropylene following fabrication guidelines
<p>N95 Respirator</p>	Filters 95% of very small particles when tightly fitted	For frontline health workers. Community use is discouraged so more masks are available for healthcare workers.	Requires professional fit-testing to be fully effective	Extended use or reuse requires following CDC guidelines	Manufactured using specialized materials and processes

*Cleaning instructions for homemade cloth masks

- To wash, launder the mask often in your washing machine in HOT water using soap or detergent that leaves no residue.
- Dry on HOT in your dryer.

5. Face mask design (20')

Design one face mask for each student in small groups, with unused or cheap materials (e.g. old T-shirts, pens-markers, scissors, rubber bands, strings etc.). Students could design a digital artifact for their mask and print this outsource. This activity could be more structured if an Art teacher could co-teach the lesson.

6. Face mask creation (15')

The creation of the masks could follow the guidelines given by WHO or Intermountain Healthcare, University of Utah Health and Latter-day Saint Charities.

Tutorial

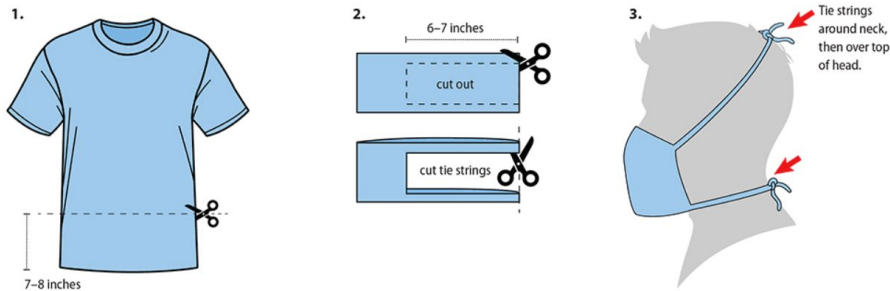

Tutorial

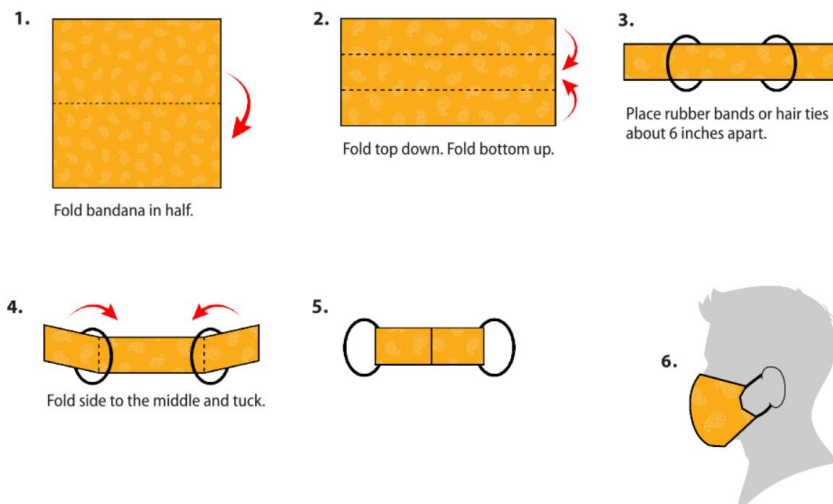

At the end of this lesson plan, students will be able to share the opinions (another way is to create a short evaluation form for students to express their satisfaction).

Instructions for teachers

The main methodologies and techniques of the course are based on brainstorming, discussion, collaboration, information access, problem solving, teamwork, and minimal time of presentations.

It is important for the teacher to challenge the ideas of his students, retrieving their previous knowledge and then comparing them with the existing sources and facts, focusing on possible misconceptions.

The most important approach is to design a personal face masks for each student, which can be created in collaboration within small groups.

There are no assessment activities, only comparisons with good practices.

Lesson Plan 4

Course: STEAM course	
Lesson 1: Balloon Tower Challenge	
Area: Physics, Engineering, Mathematics, Art	
Grade Level: Primary School (years: 2-4)	Timeframe: 45 min – 1 hour
<p>Lesson Overview:</p> <ul style="list-style-type: none"> Students are asked to build the tallest, most cost-effective, free-standing tower using only balloons and paper tape. The classroom is divided into groups of four. The teacher provides them with the appropriate material and give them instructions on how they will work. Each student is assigned with a specific role, as in order to build a stable and tall tower they will have to work as a team that each of its members will be responsible for a certain part. In the groups of four there are 3 roles: the architect that draws and calculates the tower's height, the 2 builders that are responsible for constructing the tower following architect's instructions and the economist whose role is to calculate and advise his/her team on how they will spend their available resources. Moreover, when they use the balloons and the paper tape pieces they have to be careful as 'they have to pay'. At the end the team that wins the challenge is not only the one who built the tallest tower but also the one who spent less money. 	
<p>Objectives:</p> <p>Upon completion of this Lesson students will be able to:</p>	

- Understand why it is difficult to build a stable tower using balloons (physics)
- Calculate the height of the tower using the appropriate equipment (math)
- Understand the importance of resources
- Understand the different roles in teams and in jobs and how important each of them is
- Work during limited time, more concentrated using organizational strategies

Material/ resources

- Balloons (multi-colored)
- Paper tape
- Ruler
- Blank sheets
- Pencils
- Eraser

Lesson Activities

1. Assigning Roles (5 minutes)

This lesson plan can take place either in the classroom or in the laboratory, in both cases teacher has to make sure that students have enough space in their tables in order to build their towers. In this first activity students, in groups of four, discuss and choose the role they want to have in their team. Each student describes his/her interests and tries to find the role that fits more to him/her.

2. Designing (10 minutes)

The team has 10 minutes to design the tower. In this activity the whole team discuss, and the 'architect' is responsible for drawing the tower. If team has enough time and they wish, they can decide on which colours they will use so that they will make their tower look more appealing. However, during this activity it is important to remember that the most important element is the stability as due to the lack of weight it is not an easy task for the tower to be stable.

3. Building the tower (20 minutes)

Now the teams are ready to start building the tower. They will have only 20 minutes, so in this case they should also work carefully and all together. In this activity students will understand important concept of physics and also, they will have to manage the given time. Students will 'buy' their materials by the teacher. That means that they also have to be careful on how much money they spend. At the end of this activity, students use their rulers so as to calculate the tower's height.

4. Calculate the cost (10 minutes)

In this last activity, the team reports to the economist how many balloons and paper tape pieces they used. Then the economist sums the money spent.



At the end of the activities, teacher could ask his/her students which tower is more appealing to them. The tower that got the most votes wins 10 extra points.

Instructions for teachers

- In each stage the teacher is responsible for following the course of this lesson plan. Students are asked to work in teams with separated roles. This lesson plan is a project-based lesson.
- For the assessment the teacher fills out the following table. The team that has a stable, taller and most effective tower wins the challenge.

Points will be awarded as follows:

Height of Tower	Cost Efficiency
Tallest tower – 15 points	Cheapest tower – 15 points
2nd tallest – 13 points	2nd cheapest – 13 points
3rd tallest – 10 points	3rd cheapest – 10 points
4th tallest – 8 points	4th cheapest – 8 points
5th tallest – 6 points	5th cheapest – 6 points
6th tallest – 4 points	6th cheapest – 4 points
7th tallest – 2 points	7th cheapest – 2 points
8th tallest – 1 point	8th most expensive – 1 point

Reference list (include if needed)

- N/A

Other Comments

Costs

- Balloons: 2€/ balloon
- Paper Tape: 1€/ piece

Spain

Lesson Plan 5

Course: STEAM in the classroom	
Lesson: STEAM Females	
Area: STEAM females in computer programming (Technology and combination of areas)	
Grade Level: 5-6 th Class (10-12 years)	Timeframe: 2 x 40 minutes

Lesson Overview:

- Students will research STEAM role models with a focus on female role models of the past initially. They will research those making a contribution to science past and present using a WebQuest challenge. They will research their biography including background, education, career path and achievements and impact on the STEAM industry. They will analyse the potential role model for characteristics, choices and decisions that impacted their knowledge, skills and attitudes critical to their success. They will also consider any other influences critical to the STEAM female's success based on their research including challenges as well as supports. This first challenge focuses on Ada Lovelace and computer programming.

Objectives:

Upon completion of this Lesson students will be able to:

- Identify potential Female Role Models in the STEAM industry (past and present).
- Identify STEAM pioneers who shaped the course of history.
- Analyse the career path of potential role models for critical decisions that impacted their career path.
- Identify and list any critical factors that improve the chances of success in a career trajectory.
- Describe the key achievements of the scientist.
- Identify any potential role models in the life of the STEAM expert.
- Research, identify and describe the contribution of the expert to their field of interest.
- Consider if they are interested in any aspects of the STEAM career or imagine themselves in any part of the field.

Material/ resources

1. Laptop and interactive white board or computer lab.
2. Record the evidence in an online format.
3. Web sources of interest:
 - Britannica (2020) {<https://www.britannica.com/biography/Ada-Lovelace>}
 - World Science Festival (2013)
https://www.worldsciencefestival.com/2013/10/happy_ada_lovelace_day/

- Wilpott, Z. (2017) Ada Lovelace The Original Woman in Tech, TedX Bucharest, (2017) <https://www.youtube.com/watch?v=1QQ3gWmd20s>
- Evans, Claire, The Story Behind The World's First Computer Programmer, <https://www.youtube.com/watch?v=Tkg8FdwfvIU>
- Sullivan, Crystal (2018) "Ada Lovelace The First Computer Programmer" <https://www.youtube.com/watch?v=IZptxisyVqQ>
- Adafruit Industrie, (2020) <https://www.adafruit.com/about> (Adafruit industries, 2020)

Lesson Activities

Identifying Significant STEAM Females of the past and present (2 x 40 minutes)

Students will be challenged to research STEAM females of the past and present beginning with Ada Lovelace.

Using a WebQuest challenge. Students will research STEAM Female biography including background, education, career path and achievements, impact on the STEAM industry. They will analyse the potential role model for characteristics, choices and decisions that impacted their knowledge, skills and attitudes critical to their success. They will also consider any other influences critical to the STEAM females success based on their research including challenges as well as supports.

- Setting: Classroom based using interactive whiteboard and iPads or a computer lab.
- Project based Learning
- Group work and research work
- Standard elementary class group 25-27 children.
- Ages 10-12 years.
- Using digital competences,
- Developing Information and Data Literacy, browsing, searching and filtering data, information and digital content.
- Communication and Collaboration
- Digital content creation through
- Problem Solving through research-based methods.
- Evaluating the evidence generated by an investigation.

4. Identifying Significant STEAM Females of the past (Ada Lovelace) (40 minutes).

Students will be challenged to research STEAM females of the past and present beginning with Ada Lovelace.

Using a WebQuest challenge, students will research STEAM Female biography including background, education, career path and achievements, impact on the STEAM industry. They will analyse the potential role model for characteristics, choices and decisions that impacted their knowledge, skills and attitudes critical to their success. They will also consider any other influences critical to the STEAM females success based on their research including challenges as well as supports.

5. Identifying Significant STEAM Females of the past (Ada Lovelace) (40 minutes) Assessment.

Students will be assessed based on how they carry out the investigation in the form of a WebQuest in pairs/small groups of 3 (depending on the class size). They will be observed and assessed as they investigate and inquire through web searches and discussion. They will also be observed in their planning, identifying of alternatives, and assessing/evaluating the information as well as in the context of the digital competences.

Student's learning will be **assessed** using **the digital competence framework** and using their response to the learning objectives:

- **Information and data literacy:** in the context of the WebQuest, observe and assess how students locate and retrieve data, the decisions they make on storing, managing and organising the content one of the most critical aspects; evaluating its relevance.
- **Communication and collaboration:** students will be communicating and working in the classroom as well as online on the digital platform. How the students work together in class and on the digital platform, how they share their research digitally, and make decisions on how they present their research should be observed. Students should be aware of behaving

responsibly online, and will be observed in how they demonstrate this, this is described as “netiquette”.

- **Digital Content Creation:** students will observe content online and respond accordingly, creating their own records through completing the WebQuest. At the end of the WebQuest, the students can be asked to develop an infographic, showing the timeline and key points in Ada’s career. With this output at the end, teachers will observe the process by which students assess, interpret the data, modify, and add their own viewpoint and knowledge to the existing body of online data. In summary the re-interpretation of data and integration of new ideas, opinions or viewpoints.
- **Safety:** Students will demonstrate awareness of staying safe online, assessing awareness of following safe online practices, keeping identity safe, etc.
- **Problem solving:** the overall task enables students to engage in problem solving and inquiry-based learning; in this case a digital means which can be assessed. Students gain awareness of their own digital competence, and their ability to work together on task.

Reference: EU digital competence framework 2020:

<https://ec.europa.eu/jrc/en/digcomp/digital-competence-framework>

Instructions for teachers

Using the WebQuest challenge to research STEAM female role models, teachers can adapt the lesson to suit the learning styles of the students. The web research provides visual learners with visual material, videos, diagrams, representations of data on the subject. At the same time, aural learners can listen to the information being shared online, hearing the data on the subject. All the while, the experiential learner is engaged in the whole process. The project-based and enquiry-based learning brings all learning styles together in the group task.

It is important for the teacher to demonstrate what is required, using a search engine for a specific idea/article prior to issuing the challenge.

The teacher then completes the following steps:

1. Ask all students if they know what computer programming is? Ask them to share their ideas and definitions with the class.
2. Read aloud the challenge, while displaying the WebQuest on the interactive board. If delivering the session in the computer lab, teachers need to demonstrate where the students need to go online, following the challenge. The teacher should use the WebQuest challenge worksheet in hard or soft copy.
3. Read aloud the scenario from the WebQuest challenge:

(Today you are going to travel back in time to research who the first computer programmer was. Imagine this person was the beginning of the computer technology you have in your hands! Without this person, you might not have computers, mobile phones, televisions and more!

You are using this persons' invention and so begin by searching for them and bring back as much relevant information as you can)

1. Open the search engine and look for the world's first computer programmer.
2. What do you need to find out about this person?
 - **Background**, education, career path and achievements, impact on the STEAM industry.
 - Any potential role models or people in their life who influenced them.
 - Look for characteristics, choices and decisions that impacted their knowledge, skills and attitudes critical to their success.
 - Did the challenges impact their life choices, their career?
 - What may have been their sources of inspiration?
 - Do you think they enjoyed the work they did? Why?
3. From the research, guide students through how to develop a poster or infographic to display what they have learned in this session. This poster can be developed online, using Canva for example, or if there is insufficient access to IT resources, students can draw their poster or infographic using paper, colouring pencils and markers.
4. Once all of the poster and infographics are completed, the teacher should take the work of each group, and mount the posters on the walls of the

classroom, or of the school hallways, so as to encourage other classes and students to learn about STEAM Females.

Reference list (include if needed)

- Editors (2020) biography.com Ada Lovelace biography retrieve from {<https://www.biography.com/scholar/ada-lovelace>}
- Editors (2020) Computer history museum, Ada lovelace retrieved from {<https://www.computerhistory.org/babbage/adalovelace/>}
- Editors (2020) Encyclopedia Britannica “Ada Lovelace British Mathematician” retrieved from {<https://www.britannica.com/biography/Ada-Lovelace>}
- European Commission (2019) EU “Digital Competence Framework” EU Science Hub retrieved from {<https://ec.europa.eu/jrc/en/digcomp/digital-competence-framework>}
- Morais, B. (2013) Ada Lovelace; The First Tech Visionary {<https://www.newyorker.com/tech/annals-of-technology/ada-lovelace-the-first-tech-visionary>}
- Philpot, Z. (2017) video file “ Ada Lovelace The Original Woman in Tech Zoe Philpot TEDx Bucharest” retrieved from <https://www.youtube.com/watch?v=1QQ3gWmd20s>
- Smith, Marash, Claire, Happy Ada Lovelace day (2020) retrieved from {https://www.worldsciencefestival.com/2013/10/happy_ada_lovelace_day/}
- Sullivan, Crystal, (2018) Biographics “Ada Lovelace The First Computer Programmer” <https://www.youtube.com/watch?v=IzptxisyVqQ>

Lesson Plan 6

Course: STEAM Concepts	
Lesson: STEAM Concepts -Programmed	
Area: Pre-Robotics Lesson Plan	
Grade Level: 3 rd -4 th Class (8-10 years)	Timeframe: 60 minutes
<p>Lesson Overview: Children will learn the simple concept of coding and robotics, programming simple steps through role play and creative thinking. They will also look at references to simple code from past to present. Children will also discuss the implications of robotics for the future.</p>	
<p>Objectives: Upon completion of this Lesson students will be able to:</p> <ul style="list-style-type: none"> • Describe the simple concept of programming, coding and robotics-commands. • Identify and define basic algorithm through simple tasks • Use role play to illustrate how movement can be programmed • Break down steps of programming and explore very simple concepts of programming. • Analyse the human body as a structure that fulfils complex commands consistently. • Consider robotics and the future 	

Material/ resources

1. Laptop and interactive white board or computer lab.
2. Record the evidence in an online format.
3. Web sources of interest:
 - Scratch (2013): http://www.scratch.ie/sites/all/themes/scratch_theme/resources/WorkBook2.0/SeperatedModules/Solutions/ALLsolutions2013_2.0.pdf
 - Hackster.io Anavnet Community (2020) Projects Mindstorms: <https://www.hackster.io/mindstorms/projects>
 - National geographic 2020: <https://www.nationalgeographic.org/activity/how-train-your-robot/>
 - Crickit Flippy Robot: <https://learn.adafruit.com/crickit-flippy-robot> (adafruit 2020)

Lesson Activities

Children will learn the simple concept of coding and robotics, programming simple steps through role play and creative thinking. They will also look at references to simple code from past to present. Children will also discuss the implications of robotics for the future.

- Setting Classroom with interactive white board.
- Authentic learning, project-based learning using role play, creativity and web sources
- Engagement and active participation through hands-on practices
- Standard elementary class group 25-27 children.
- Ages 8-10 years.
- Monitor prior knowledge
- Wooden human mannequin, robotics, Lego.
- Link with the relevant digital competences

The project-based and enquiry-based learning brings all the learning styles together in the group task as the learners are introduced to Scratch through a simple lesson. It is envisaged students will use the weblinks provided to

undertake some research into Scratch and come up with a project idea as a result of the initial lesson.

It is important for the teacher to demonstrate what is required, using a search engine for a specific idea/article prior to issuing the challenge.

1. Read aloud the project and introduce the topic of robotics and programming.
2. Display example of robotics and coding and simple projects on the interactive board.
3. If delivering the session in the computer lab, teachers need to demonstrate where the students can go online and make notes on their research.
4. The use of role play and an initial demonstration will be very important for illustrating the core concept of the lesson.

Assessment:

Students will be assessed based on how they carry out the investigation into robotics and simple coding specifically commands as they work in teams and as part of the group. They will be assessed on teamwork, their use of the role play and discussion skills to reflect on in conclusion about robotics and the future. Throughout the lesson they will be observed at certain points in the investigation, planning, identifying alternatives, breaking the steps and commands down, practical role play and evaluating as well as in the context of the digital competences when they research coding digital clips and media files on robotics.

The students' learning will be **assessed** using **the digital competence framework** and using their response to the learning objectives.

Information and data literacy; observe and assess how students locate and retrieve data, the decisions they make on storing, managing and organizing the content one of the most critical aspects; *evaluating its relevance*.

Communication and collaboration, problem solving and creating the commands for digital content.

Instructions for teachers

1. Read aloud the project and introduce the topic of robotics and programming.
2. Display example of robotics and coding and simple projects on the interactive board.
3. Arrange the children into groups or pairs, introduce the topic of robotics and coding using the physical props in your room, robotics kits, wooden mannequin and the online clips.
4. Explain that for the robot to learn how to move or respond to any commands it needs clear definite appropriate direction delivered in a step by step fashion. Use the example of learning to dance. The dancer needs to know the steps.
5. Introduce a diagram of the body and compare it to the robot, explain that very simply the brain interacts with all the many systems of the body and provides the commands and signals to the body which in turn responds. The body is an amazing system and engages many systems and commands at the same time.
6. However, the body has learned to do this over time and just as a baby learns to do everything in stages, the robot will need to learn step by step.
7. Simple commands are the goal of today's task.
8. Ask the class to try to "floss", show the dance on screen, they are engaging two different parts of their body in opposite movements at the same time. Ask them to test the floss movement with their wooden mannequin and compare the results?
9. The wooden mannequin does not have the flexibility and dexterity of the human body.
10. Ask the class if they would like a robot to assist them with any tasks. Limit the tasks to physical tasks like carrying a book. Ask for volunteers in the groups, one student role plays the scenario and the remaining student(s) call out commands to test instructing them to carry the book.
11. The volunteers cannot move without being given clear direction, they must imagine themselves as robots who cannot move, the other person is the brain or control centre telling each limb to move. Insist that there are

no movements without clearly defined steps. They must imagine they are using their body to process and make these movements for the first time.

- 12.** Refer to examples online of robot commands and act this out.
- 13.** Ask the class to come up with a variety of tasks that they can role play.
- 14.** Introduce the word “algorithm”, a set of tasks/steps in a sequence, explain that they have just role-played what an “algorithm” looks like. Ask them to look up this term. Remember to refer them to early computer programmers like Ada Lovelace, who they will learn about in the other lesson.
- 15.** Ask them if they know any other words linked to computer programming?
- 16.** Ask them to put these words into a search engine and discuss what these terms mean.
- 17.** IF the robot had fallen, what might have been the problem? Following this, ask them to think about bugs and debugging if this has not arisen.
- 18.** Ask them to look at simple examples of robotics online and share the links provided.
- 19.** Ask the groups to come up with their own role play and their own list of steps-algorithm to accompany the task.
- 20.** Ask the class to search for scratch coding online and find an example of simple scratch that you would like to investigate. Use the links suggested if useful.
- 21.** Ask them to compare and contrast the language they have used in their scenarios with the language of the coding cited here.
- 22.** Ask them to make any modifications or adjustments based on what they are looking at. They will be taking a simple task and preparing it for Lego Mindstorms.

Reference list (include if needed)

- Adafruit (2020) Crickit Flippy Robot <https://learn.adafruit.com/crickit-flippy-robot>
- edX 2020 Robotics overview and courses {<https://www.edx.org/learn/robotics>}

- Flipped Classroom Tutorials (2018) Scratch Coding a complete overview for beginners {<https://www.youtube.com/watch?v=KOT7zuxElgw>}
- Lego Discover (2015) How to program tutorial (learn to program tutorial) Lego Mindstorms 1 <https://www.youtube.com/watch?v=81hctQt6Cp8>
- Lego Discover (2018) How to make your robot react (learn to program tutorial) Lego Mindstorms -3 {<https://www.youtube.com/watch?v=QYHYA-d-8M>}
- Lego Education (2020) {<https://education.lego.com/en-us/support/mindstorms-ev3>}
- Lego Education (2020) {<https://education.lego.com/en-us/support/mindstorms-ev3/getting-started>}
- Lego Fantube (2018) {<https://www.youtube.com/watch?v=gbLv0k40wrs>}
- MIT (2019) Scratch Overview {<https://www.media.mit.edu/projects/scratch/overview/>}
- MIT (2020) Scratch community {<https://scratch.mit.edu/>}
- MIT media lab (2017) {https://www.youtube.com/watch?v=_q2RgQMc96k}
- MITK12 Videos (2016)How to make a video game {<https://www.youtube.com/watch?v=Ex1ktxOxVgl>}
- National Geographic 2020 {<https://www.nationalgeographic.org/activity/how-train-your-robot/>}
- Out-school (2020) <https://outschool.com/classes/introduction-to-robotics-build-and-program-a-real-robot-with-microbit-sUNQmOFw?sectionUid=ef066277-ad3e-4a7b-97b9-e931974b6953#abkc1zlb7w>
- Projects Mindstorms <https://www.hackster.io/mindstorms/projects> (National geographic 2020)
- Scratch (20213) Scratch Workbook Solutions http://www.scratch.ie/sites/all/themes/scratch_theme/resources/WorkBook2.0/SeperatedModules/Solutions/ALLsolutions2013_2.0.pdf
- Scratch Ed (2011) intro to scratch <https://www.youtube.com/watch?v=ywG6lv9mFLI>
- Scratch Ed Learn Share Connect (2020) (<http://scratched.gse.harvard.edu/>)
- Scratch Team (2017) getting started with scratch <https://www.youtube.com/watch?v=ssoRNCtmhVM>



Netherlands

Lesson Plan 7

Course: STEAM	
Lesson 1: Build your own Salt Sculpture	
Area: Chemistry and Art	
Grade Level: Primary school (age 9 -11)	Timeframe: 30-40 min
<p>Lesson Overview:</p> <p>In this lesson you will build an artwork on which you will grow salt crystals. You will keep a log over during the time the salt crystals are forming.</p>	
<p>Objectives:</p> <p>Upon completion of this Lesson students will be able to:</p> <ul style="list-style-type: none"> • Grow salt crystals and know how they are formed • Understand what atoms are • Keep a log of their experiment 	
<p>Material/ resources</p> <p>Please number all the instructional tools/resources material you will use in your lesson with a short title and source for copyright issues (include references were needed in the relevant section).</p> <ul style="list-style-type: none"> - Pan/kettle - Kitchen Salt (400 gram) 	

- Water (1 liter)
- Wire/Thread/Yarn
- Toothpicks/skewers
- Bowl
- Wisk
- Optional: colour pigment or dye



Lesson Activities

1. Growing Salt Crystals (40 min)

The salt crystals can be grown in the classroom or at home.

Building of the artwork:

Start with making artwork from wire/thread/yarn which should fit inside the bowl/container you are using. You can also use toothpicks or small wooden skewers or sticks to build your frame for the salt crystals to grow on!

Instructions salt solution:

- Bring water to a boil
- Add the salt and mix well till all the salt is dissolved (be patient, it might take a bit of time! Keep stirring)
- When all the salt is dissolved, pour the water in a transparent container/bowl
- Place your creation of wire/thread/yarn in the water so it is partly submerged or touches the water enough so it can suck up the water
- Place the container on a warm spot (in the sun or near a radiator)

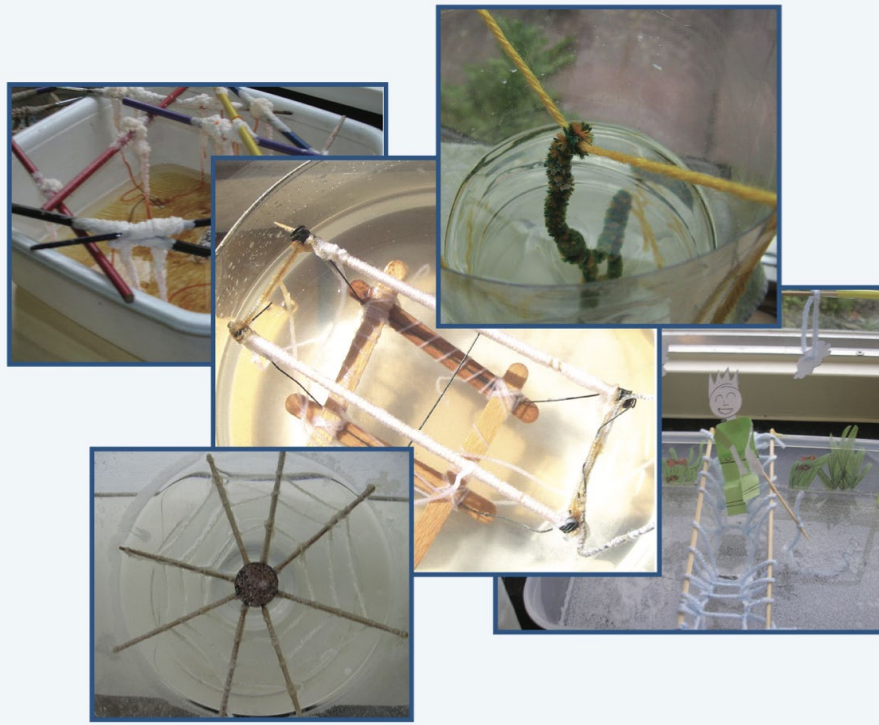

It can take a very long time before you see crystals forming: sometimes two or three weeks. That's why you need a little patience. But you usually see the first crystals appear after a few days. On a warm spot your crystals will grow faster since the water will evaporate faster.

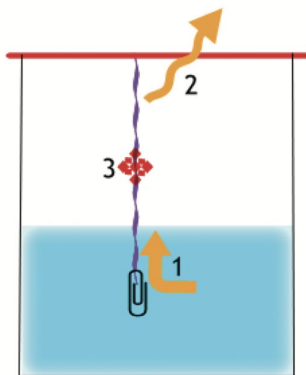

How do salt crystals form?

1. The saline solution is drawn into the thread
2. The water evaporates due to the heat.
3. The salt remains and these become salt crystals

2. Keeping a log (2-3 weeks)

Scientists write very precisely how they conducted their experiments, often referred to as 'keeping a log'. Keeping such a log is very useful: you will know exactly what you did later on. Now that you are going to build a salt crystal yourself as a scientist, you should of course also make a log! For example, write a piece every day or take pictures of your crystals. You also write down everything that goes wrong in your logbook.

Instructions for teachers

Background information

The story behind your salt crystal

You now know how to make salt crystals, but what actually happens when you do that? Below you can read exactly what happens in your saline solution.

Water and salt are not alike. Salt consists of grains and water is a liquid at normal temperature. When we dissolve the salt in the water, we have a mixture. In that case, the salt particles float in the water.

As long as you use a little bit of salt, salt dissolves well in water. But if you dissolve a lot of salt in water, the water will be "full" at some point - no more salt can be dissolved. We call this a saturated solution. If you add more salt, the extra salt will simply remain in the bottom of your cup as granules.

You can compare it to a classroom where there are chairs, but where there are no children. If the teacher lets a few children into the room, they can all sit on a chair. But when the teacher puts a lot of children in the classroom, at some point all the seats are taken. The children who then remain must stand, just like the salt grains at the bottom of the cup.

After you make the saturated solution, put the solution on a warm one spot, causing the water to evaporate little by little. But because water evaporates, there is also less room for the salt to dissolve! The more water evaporates, the more salt becomes solid salt again. Think of the example of the classroom; if the classroom is full and the teacher removes the chairs one by one, more and more children have to stand.

Maybe the children are not happy that they have to stand. But when salt can no longer dissolve, it forms salt crystals. And that's not bad, that's fun! A crystal is a solid that has a very regular structure. Below you see a picture of a salt crystal. Just look: all the balls are neatly attached to each other in the same way. We call these balls 'atoms'.

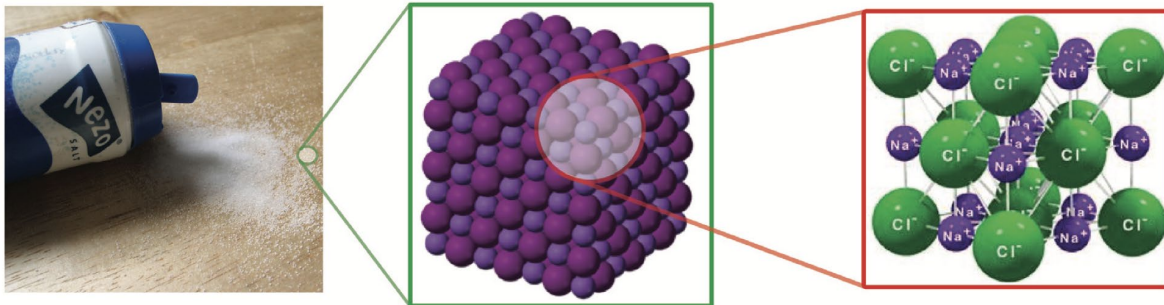

But what exactly are atoms? Atoms are the building blocks of everything you see: the whole world around you is made up of atoms. Atoms are enormously small, so small that you can no longer see them even with a microscope. Well, except with the very best microscopes. There are over a hundred different atoms and everything around you is made up of them. There are two different types of atoms in a salt crystal. We call these sodium atoms and chlorine atoms. They are always sitting next to each other, and also above and below each other, layer after layer after layer. In the picture of the salt crystal, the small spheres are the sodium atoms and the large spheres are the chlorine atoms.

If you make salt crystals by evaporating water, that crystal builds up slowly. One by one the sodium and chlorine atoms join together: atom after atom, layer after layer. The piece of crystal that you see in the picture is just a very small piece of a grain of salt: it contains many more atoms.

In real life, atoms have no color: not purple, not pink, not yellow, not green. We often draw them with a color, but that is because then you can clearly see the difference between the atoms.

Back to the crystals: Crystals are also found in nature. Snowflakes are examples of crystals, but also gemstones such as diamonds are crystals that you can find in nature. In the pictures below you can see a number of beautiful crystals from nature. As you can see, crystals come in different shapes!

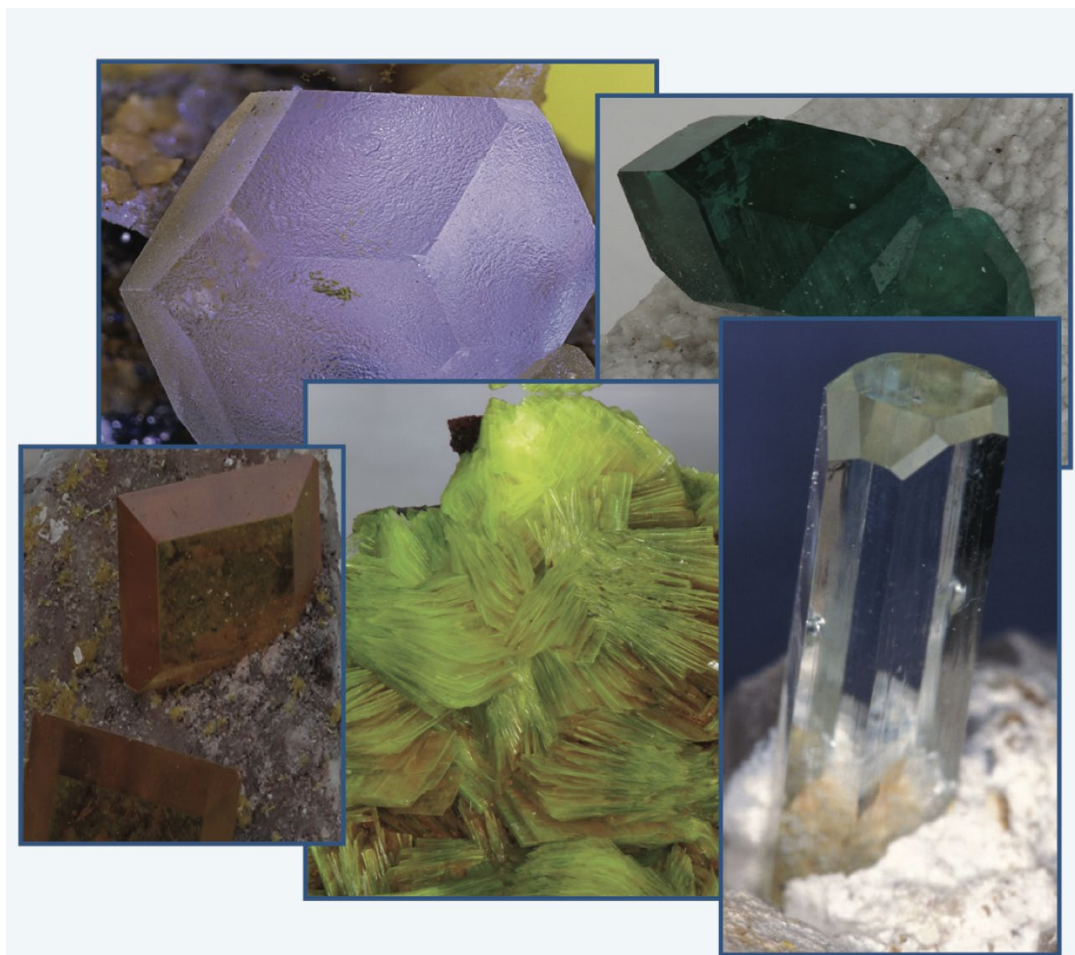

Crystals in science

Some scientists find it fun and exciting to look at crystals. But they don't look at the color or the shape, but how the atoms in the crystal are connected. And that differs from substance to substance: the atoms in a salt crystal are attached to each other very differently than the atoms in diamond.

Reference list (include if needed)

So, you now know what happens when you make salt crystals. Moreover, you know that crystals are not only beautiful, but also very useful. Do you want to

know more? More information can be found at www.zoutkristallen.nl (in Dutch). Here you can find fun facts and stories about salt, such as where salt comes from and how it ends up on the table. Also here are the logs of other children and you can leave messages in each other's guestbook.

Lesson Plan 8

Course: Acids and Bases

Lesson: Colourful kitchen chemistry

Area: Chemistry

Grade Level: Primary School
(from year 1)

Timeframe: 30-40 min.

Lesson Overview:

- DIY kitchen science, to do at school or at home. Almost everything you need can be at home or at the supermarket. Anyone can do it, enjoy!
- two colourful experiments: 1. rainbow skittles and 2. colourful cabbage

Objectives:

Upon completion of this Lesson students will be able to:

- be curious to find out how things work, and see science is everywhere around them
- understand some chemistry behind colour changes
- know the difference between acids and bases

Material/ resources

Experiment 1, rainbow skittles:

- Skittles
- plate
- boiling water

Experiment 2, colourful cabbage:

- a red cabbage (fresh or in a jar)
- a tablespoon
- a small bowl
- a pan
- a knife
- liquids you want to test for their acidity
- a glass

Description of each Activity

- Setting: the activities can take place either in a classroom, an outdoors place, or in the kitchen. They were in fact designed as experiments to be carried out at home but they could be implemented in various contexts.
- The activities are hands-on are designed based on a problem-based approach and experimentation that requires active engagement by the learners
- The activities are designed to be carried out in small groups (3-4 students) to maximize active engagement. They could be implemented in a classroom with a typical size of 20-25 students, and not more than 6 groups of students per one teacher.
- There is no prior knowledge that is required but observation and simple experiment skills are essential.
- The only materials required are the following for each group of students
 - a red cabbage (fresh or in a jar)
 - a tablespoon
 - a small bowl
 - a pan

Lesson Activities

1. Make a drawing of a rainbow: what are the colours and in which order?
2. Place the Skittles in rainbow order at the edge of the plate (10 mins)
3. The teacher pours boiling water in the middle of the plate, until the Skittles are in water up to half-way. (5 min.)
4. Describe what is happening and ask how it works. Explanation: The heat of the water causes the dyes on the Skittles to become liquid and mix with the water. The dyes move most easily to places where there is no other dye, which is why the dyes move towards the centre.
5. When the water has cooled down you can eat the Skittles :)

4

RAINBOW

HOW DOES IT WORK?

 The heat of the water causes the dyes on the Skittles to become liquid and mix with the water.

The dyes move most easily to places where there is no other dye, which is why the dyes move towards the centre. This is similar to the way in which the black ink was pushed up by the water into the coffee filter.



4

RAINBOW

WHAT DO YOU NEED?

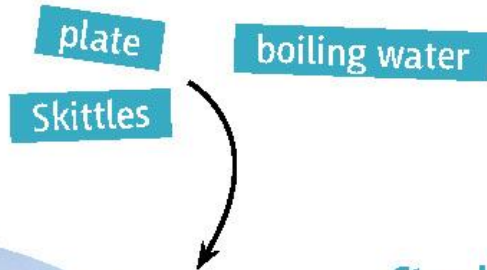

Did you know that **red**, **orange**, **yellow**, **green**, **blue**, **indigo** and **violet** are the colours of the rainbow?
Make one yourself!

Step-by-step plan

- 1 Place the Skittles in rainbow order at the edge of the plate.
- 2 Ask an adult to pour the boiling water into the middle of the plate until the Skittles are in water up to half-way.



TIP! When the water has cooled down you can eat the Skittles!



Please add the

Colourful Cabbage (fresh)

1. Cut up part of the red cabbage into small pieces (teacher)
2. Put the pieces into a pan and add some water
3. Cook the cabbage (teacher)
4. Turn off the hob and let it cool down
5. When everything has cooled down, drain the red cabbage juice through a sieve into a bowl.

Colourful Cabbage (from a jar)

6. Skip step 1-5. Drain the red cabbage juice into a bowl or glass.

Now the real experimenting can begin!

Pour a little purple water into a glass and add a liquid that you want to test. For example, water, vinegar, lemon juice, soapy water or baking soda in water. The liquids change from purple to a different colour. They turn green/blue, purple or red.

7. Also fun: Mixing different colours. What happens now?

This is the most important step in assessing the students learning: what do they observe? Is this what they expected, and why? If not, why is it different?

Insert Assessment Activity Title (Timeframe)

Summative assessment at end of the lesson

Summative assessment is done through an online science quiz at the end of the lesson where students are asked to respond to various questions around the science concepts introduced in the activities. Below there are 4 indicative questions.

1. What causes the color changes? (Peha or acid base)
2. An acid can neutralize the base (true or false)

3. A base can neutralize an acid (true or false)
4. What can the color of an indicator tell you about the substances added to it?

Formative assessment throughout the lesson:

Formative assessment will take place throughout the activities through two ways:

- a) observations of the ways in which students engage with the activities (e.g., active role with experimentation, enthusiasm, interaction and collaboration with other students)
- b) whole-group discussion around questions related to the process of experimentation as well as transfer of scientific knowledge to everyday life settings:
 - what did you observe?
 - why did this happen?
 - what would happen if we added more soap or baking soda?
 - what happens when people have stomach-pain?
 - how is the water in swimming pools tests for its acidity?
 - What are some things acids and bases are used to make?
 - What makes a weak base?
 - What makes a weak acid?
 - Why is water important to acids and bases?
 - What are strong acids?
 - What are weak acids

2

COLOURFUL CABBAGE JUICE

WHAT DO YOU NEED?

a red cabbage (fresh or in a jar)

a pan

a tablespoon

a small bowl

liquids that you want to test

a knife

a glass

All kinds of different substances can magically change the colour of red cabbage juice. Try it yourself.



Step-by-step plan

(fresh red cabbage)

- 1 Ask an adult to cut up part of the red cabbage into small pieces.
- 2 Put the pieces into a pan and add some water.
- 3 Ask an adult to cook the cabbage.
- 4 Turn off the hob and let it cool down.
- 5 When everything has cooled down, drain the red cabbage juice through a sieve into a bowl.

Step-by-step plan

(red cabbage from a jar)

- 1 Drain the red cabbage juice into a bowl or glass.

Now the real experimenting can begin!

- 6 Pour a little purple water into a glass and add a liquid that you want to test. For example, water, vinegar, lemon juice, soapy water or baking soda in water. The liquids change from purple to a different colour. They turn green/blue, purple or red.

Also fun: Mixing different colours.

What happens now?

2

COLOURFUL CABBAGE JUICE

HOW DOES IT WORK?

The red cabbage juice is what we call an indicator. If you add acids such as citric acid or vinegar, the colour of the juice changes from purple to red because the substances in the red cabbage juice change into other substances with a red colour.

Baking soda and soapy water are the opposite of acids: bases. These substances also react with the red cabbage juice but this time it changes into a blue/green substance.

If a substance is not an acid or a base, such as water, it does not react, and the juice stays purple. Acids and bases react together to form water. So mixing blue and red will give you purple again.



Role of teachers:

The teacher acts as a facilitator walking from group to group checking for understanding through questioning with the group. Important decisions to make include the formation of the groups to ensure balanced interactions and power dynamics and assigning equally agentic roles to the students.

The teacher also provides feedback on the work-in-progress alongside positive reinforcement to each group.

Student scaffolding can be achieved through a series of questioning and assigning of mentoring roles within the group.

Student learning can be examined during this process through questioning as a form of a summative assessment.

Instructions for teachers:

Colourful Cabbage explained

The red cabbage juice is what we call an indicator. If you add acids such as citric acid or vinegar, the colour of the juice changes from purple to red because the substances in the red cabbage juice change into other substances with a red colour.

Baking soda and soapy water are the opposite of acids: bases. These substances also react with the red **cabbage juice but this time it changes into a blue/green substance.**

If a substance is not an acid or a base, such as water, it does not react, and the juice stays purple. Acids and bases react together to form water. So mixing blue and red will give you purple again.

Want to explore more?

Use this method to measure the acidity of the soil in your neighbourhood:
<http://smarkidslab.nl/content/english/1-ph-meter-maken/SmartKidsLab-Measure-acidity.pdf>

Reference list (include if needed)

<https://www.rug.nl/sciencelinx/zpannendzernike/proefjes-om-thuis-te-doen>

Measure acidity of red cabbage (in Dutch only):

Video and overview: <https://www.skillsdojo.nl/smartkidslab/zuur-meten-met-rodekoolsap/>

LP: http://smartkidslab.nl/content/1-maak-een-meter/1-ph-meter-maken/SmartKidsLab_Zuurmeter.pdf

Ireland

Lesson Plan 9

Course: HTML Language

Lesson: Basic HTML

Area: Technology

Grade Level: Secondary school Timeframe: 40'

Lesson Overview

Using Codecademy lessons about HTML language (<https://www.codecademy.com/learn/learn-html>), students will acquire basic knowledge about this language. After that, they'll learn how to create a basic webpage following a series of requirements.

Objectives

Upon completion of this Lesson students will be able to:

- Acquire the basic knowledge related to HTML
- Create a simple webpage using HTML language
- Add embedded content to your website using HTML (videos, images, tables)

Material/ resources

- <https://www.codecademy.com/learn/learn-html>
- Electronic devices (laptops, tablets...) for students
- Electronic device for the instructor
- A digital blackboard

Lesson Activities

1. Codecademy lessons (At home)

Students will view the HTML course at home to acquire the basic knowledge about this language. This course, *Learn HTML*, can be found at Codecademy web page: <https://www.codecademy.com/learn/learn-html>. This involves a flipped classroom approach. Students will need to have an electronic device to follow the lessons.

2. Creating a webpage (25')

Students, in groups of 4, will create a webpage using HTML language. Each webpage must include these concepts:

- Insert a table
- Insert an image
- Insert a YouTube video
- Insert a minimum of 3 different types of titles.

This activity will be done in class using one computer per group.

3. Presenting the webpages (15')

Each group will present the webpage they created using HTML language to the rest of their classmates. It must be a short presentation, the duration of each one will depend on the number of groups there are.

Instructions for teachers

- The inclusion of a video that students should watch previously, following the Flip classroom methodology, will enable each student to follow their own pace and pause the video whenever need it.
- Then, in the classroom, the teacher will be able to check if students fulfill all the requirements and include all the compulsory elements. If there is a recurrent doubt or mistake, it could be explained to the whole class by the

teacher, using a projector or a digital blackboard. Feedback will be given simultaneously.

- The cooperative and collaborative aspect of the lesson will enable students to participate and acquire teamwork skills while acquire HTML knowledge. Moreover, the topic of the different webpages created will be totally free, thus encouraging the involvement and motivation of students.
- If needed, the teacher will include more elements for those groups that finish early.

Reference list (include if needed)

<https://www.codecademy.com/learn/learn-html>

Lesson Plan 10

Course: Programming with Scratch

Lesson: Basic knowledge about Scratch

Area: Technology

Grade Level: Primary

Timeframe: 40'

Lesson Overview

This lesson will provide students with basic knowledge about how to basically program through Scratch, an online easy-to-use tool for that purpose. For example, they will learn some of the basic commands and put them into practice. They will later be able to try it in one experiential workshop, using Makey Makey.

Objectives

Upon completion of this Lesson students will be able to:

- List the commands needed for basic programming
- Acquire a basic knowledge of the proposed online tool
- Use the different commands learned

Material/ resources

- Scratch (<https://scratch.mit.edu/>)
- Digital devices (computers, tablets, etc.) for students
- 5 templates or educational boards to carry out different tasks in different levels

Lesson Activities

1. How to use Scratch (20 minutes)

The activity will take place in the classroom and will consist of an explanation by the tutor of the main commands and uses of the Scratch tool.

The whole class will attend this first activity.

The materials needed are an electronic device for the teacher and a screen on which he can show his students the basic concepts of the lesson.

Link to the Scratch tool for programming: <https://scratch.mit.edu/>

2. Using Scratch (20 minutes)

To put into practice what has been learned, an activity will be carried out in which students, in groups of 4, will have to face different challenges. Different templates will be used, with progressive difficulty, which they will have to complete in order to solve all of them. The templates will present different challenges, such as including sounds or executing the directions. This activity will be done in the classroom using on computer or digital device per group.

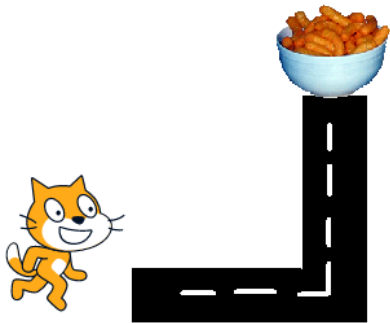

3. Creating Scratch routes (if there is time left)

If students complete the 5 templates before time ends, they can create their own templates, so they can continue with the programming activity.

Instructions for teachers

The progressive difficulty of the different templates will enable every student to follow their own pace. In order to start working on the next template, the teacher must check that all requirements have been fulfilled. The number of templates finished by each group will give the teacher a clear insight on the students' knowledge acquisition. Therefore, if one group finishes all the given tasks, it will be a great indicator of this knowledge acquisition. When doubts and mistakes are recurrent, the teacher could explain one specific aspect to the whole class. Explanations will be shown on the projector or digital blackboard, being it of great usefulness for students. The playful characteristic of the activity will encourage the motivation and involvement of students. The templates will progressively increase their difficulty, which will allow students purchase greater skills and abilities progressively. As it is mentioned before, it is necessary to provide students with extra activities in order to give them the chance to continue with the lesson if they have finished the second activity before the end of the class. This way, teacher give students the opportunity to create their own template using their creativity.

UK

Lesson Plan 11

Course: Multidisciplinary Lesson

Lesson: The Great Fire of London

Area: History, Design Technology (DT) and Math

Grade Level: Lower primary level

Timeframe: 45 minutes – 1 hour

Lesson Overview:

- Hands on fun DT activity which will engage children in applying what they already know about the Great Fire of London into a moving scene. During this activity children use fine motor skills to draw and colour buildings from 1666, cut, fold and hole punch card and insert fasteners. This activity invites DT and history questions from children. These scenes can be played with and used as a writing prompt.

Objectives:

Upon completion of this lesson students will be able to:

- **Design Technology:** fold and cut paper and card, cut along lines, straight and curved, use a hole punch, insert paper fasteners for card
- **History:** use secondary source material to find out about an event
- **Math:** use measurements for materials

Material / resources:

This lesson works with a full class (20-30 children) inside a classroom. It is a hands on practical activity.

1. 1. **Pencil** (1 per child)
2. Coloured pencils / crayons (to share)
3. A5 white card (1 per child and extra for lever)
4. Scissors (to share)
5. Split pins (1 per child)
6. Hole punch (to share)
7. Images depicting the Great Fire of London (either to show to the whole class or a selection to pass around the individual groups)
8. Interactive White Board (IWB) or printed copies of images
9. Red, yellow, orange tissue paper or coloured paper (several sheets per group)

Lesson Activities:

1. **Introduction to the scenario and activity** (15 minutes)
 - Start by showing an image or short video (provided) about the Great Fire of London and explain the basic story of the event.
<http://www.fireoflondon.org.uk/collection-type/artworks/>
<https://www.bbc.co.uk/newsround/37253904>
<https://www.bbc.co.uk/newsround/37253903>
 - With the images of the fire on display discuss what we know happened during the Great Fire of London. You can prompt the discussion with questions such as:
What material are the houses made of?
What colour might the houses have been?
Describe how the houses have been built?
Are the houses close together or far apart?
How do you think this contributed to the spread of the fire?
How do we know all this?
 - If necessary, show some more images until the children have built up a clear understanding of the buildings appearance and layout (tall, close together, wooden).
2. **Create a simple diorama of a scene from the Fire of London** (20 – 30 minutes)
 - Each student will make their own diorama provide the necessary materials for the activity.
 - Model how children are to draw a row of houses themselves on cardboard (you may have pre-prepared examples ready to show each group)

Step-by-step instructions for learners:

1. Students should use the houses in the pictures as inspiration for drawing a row of houses on their piece of cardboard.



2. Colour the buildings



3. Cut along the rooftop skyline.



4. The students should now use a new piece of cardboard and fold a strip of cardboard (approx. 2cm wide) and cut along the fold. Students should use a ruler (or compare length) to ensure their strip of cardboard is longer than the line of houses.

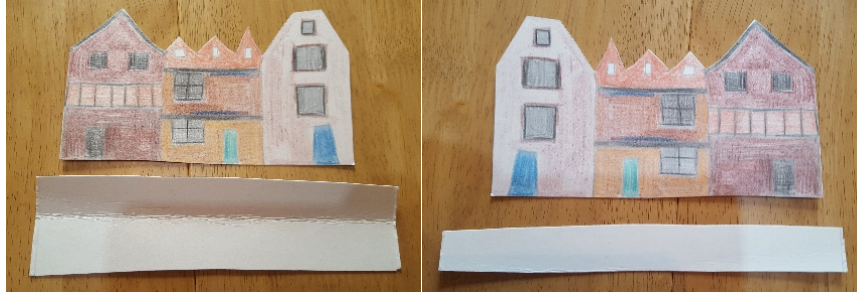

5. Create a flame effect at one end of the cardboard strip with the coloured paper/tissue paper and crayons.



6. Use a hole punch to put a hole at any point of the image.



6. The flames need to pivot up above the houses from the hole punch point and another hole put into the cardboard strip. This may take some experimentation to ensure the hole is punched in the best location for the flames to appear above the houses.



3. Final assessment and discussion (10 minutes)

- Once all of the groups have completed their dioramas then each group should go around the class and look at the other group's dioramas.
- After this, a full class discussion should take place about the activity and the Great Fire of London, you may ask them about how modern-day cities are built differently to reduce the chances of such an event happening again.

Instructions for teachers:

Prior knowledge of the Great Fire of London:

This lesson works best if the students have some prior knowledge of the Great Fire of London. The children can gain an understanding of the Great Fire of London by watching the videos provided.

Differentiation:

This activity can be differentiated by outcome.

Additional assessment of knowledge:

You may add an element of assessment of historic understanding through open and closed questioning and application of knowledge i.e.

- *What material are the houses made of?*
- *How do we know this?*
- *What colour might you colour your houses?*
- *Describe how the houses have been built?*
- *Are the house close together or far apart?*
- *How do you think this contributed to the fire?*

Assessment of DT skills through observation of children completing the activity, the amount of support required, and their understanding of instructions given:

- Student feedback during activity
- Guidance provided verbally throughout the lesson.

Other Comments:

You may wish to provide preprinted houses for the children to colour, cut out and stick onto the cardboard. Such as;

<https://www.sparklebox.co.uk/topic/past/fire-of-london.html>

Lesson Plan 12

Course: Multidisciplinary Lesson

Lesson: Solar Snacks

Area: Math, Physics and Design Technology (DT)

Grade Level: Any secondary level

Timeframe: 45 minutes – 1 hour

Lesson Overview:

- Students investigate how parabolas can focus light to heat marshmallows in a simple solar oven. This is one way that people could cook in the powerless world or if they have limited access to cooking fuels. This activity can be done in small groups of 3 or more individuals.

Objectives:

Upon completion of this lesson students will be able to;

- **Math:** understand the geometry and potential real world uses of parabolas
- **Physics:** understand how solar energy can be used and how light energy can be converted into heat energy
- **Design and Technology:** use basic resources to engineer a simple solar oven

Material / resources:

This activity works best outside on a sunny day. On a cloudy day, perform the experiment inside the classroom with a halogen desk lamp. This could perhaps also be used as a demonstration on a sunny day before going outside.

1. printed copies of the parabola (template provided)
2. A4 corrugated cardboard (four sheets per group)
3. A3 thin card (one sheet per group)
4. aluminium foil
5. glue sticks, tape
6. long bamboo or wood skewers
7. marshmallows
8. probe or infra-red thermometer
9. protective gloves
10. transparent acrylic sheet (optional)
11. halogen desk lamps for use on a cloudy day (caution: can be hot)

Lesson Activities:

1. Introduction to the scenario and activity (10 minutes)

- Imagine a world where there is no electricity or access to fuels for cooking.
- What potential ways could you use to cook food or to heat water?
- One solution that could be used is solar cooking, in this case we will focus on the concept of a **parabolic solar oven**.
- Discuss which STEAM roles might help in this situation: e.g. optical engineer, thermodynamics scientist, energy engineer, food scientist etc. **Students can take on these roles if they wish.**
- Briefly introduce parabolas and their properties.
- A parabola is a curve where any point is at an equal distance from a fixed point (the focus), and a fixed straight line (the directrix).f
- Use the link for a more detailed explanation and diagrams
<https://www.mathsisfun.com/geometry/parabola.html>

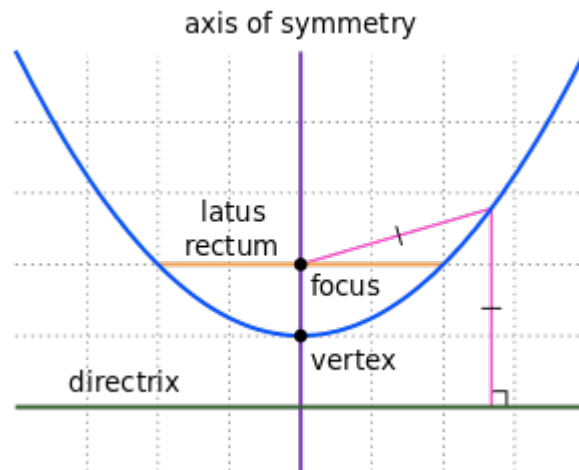

- Explain that parabolas are found everywhere in the world including;

In nature



Architecture

And.....

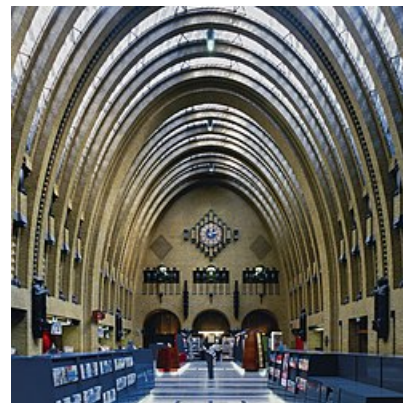

- In everyday life they are especially useful for reflecting and focusing light in torches, vehicles headlights and household light bulbs.

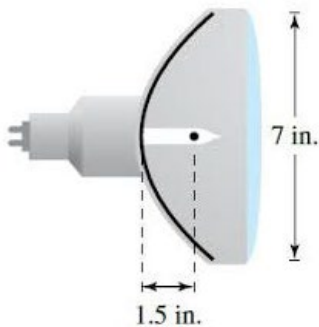

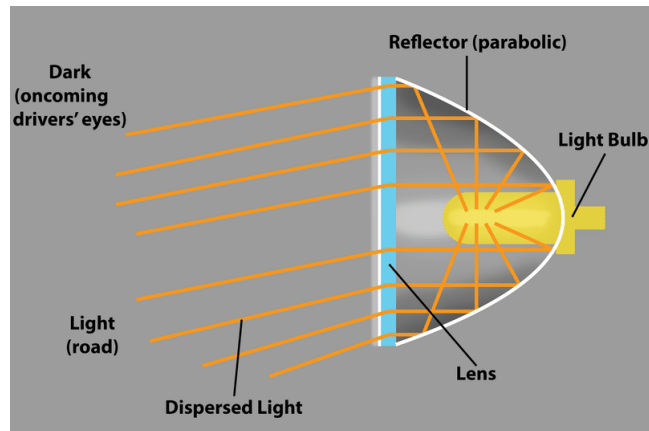

2. Build your parabolic solar oven (20 – 25 minutes)

- Guide teams as they carefully follow the step-by-step instructions to build a small reflective parabolic solar oven.
- If undertaking this outside, students can optionally use transparent acrylic sheets as a top cover, which helps trap heat. ****Do NOT try this if using halogen lamps*.***
- ***Step-by-step instructions for learners***
 1. Cut out a parabola using the template page provided
 2. Use this parabola as a template to draw a parabola shape onto each of the 4 sheets of A4 corrugated cardboard and then cut the shapes out (leaving each group with 4 individual parabolas made of corrugated cardboard)
 3. Glue two of the parabolas together to create one of double thickness, then do the same with the other two parabolas as well
 4. Use a skewer to accurately create a hole through the focus points on each of the 2 parabolas (again using the parabola template with the focus point marked as a red spot)
 5. Use the glue stick to carefully cover one side of the A3 thin card, and one side of each parabola, with aluminum foil. Make sure the shiny side faces out and try not to create wrinkles as this will reduce the effectiveness of the reflective surfaces
 6. Wrap the thin card around the curved edges of the parabolas and tape it in place to create your solar oven, this should be wrapped all-round the parabola at each end to form a kind of a parabolic trough.

****Ensure the foil is on the inside of the oven*.***

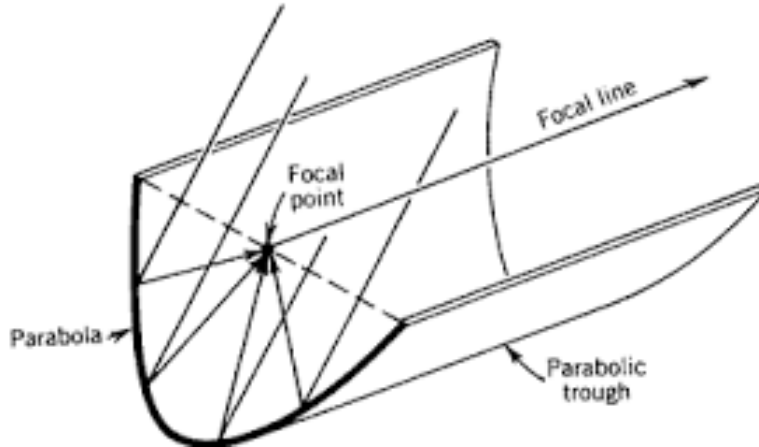

7. Slide a skewer through the pre-pierced focus points of each parabola and make sure the skewer passes straight through the oven and out each side
8. Now they have engineered a simple reflective parabolic solar oven with a cooking skewer

3. Test your parabolic ovens (10 – 20 minutes)

- Test the parabolic solar ovens with marshmallows and thermometers. See how fast the marshmallows melt, and / or what final temperature the ovens reach.
- **Step-by-step instructions for learners**
 1. It's time to cook! Load one or two marshmallows onto your skewer. Make sure they don't touch the foil, so light can reflect onto them
 2. Angle your oven to face the sun, or if inside, the halogen lamp
- ***NOTE: Take extra care if using a halogen lamp as they can generate a lot of heat and you could burn yourself. Use protective gloves and wear protective eyewear*.**

The following image below omits one side of the card/foil reflector

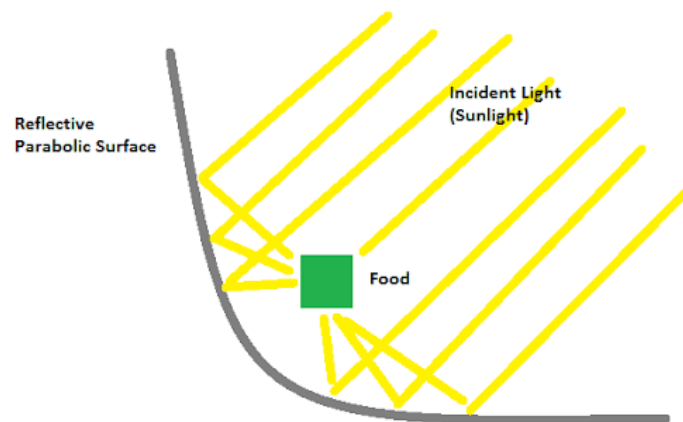
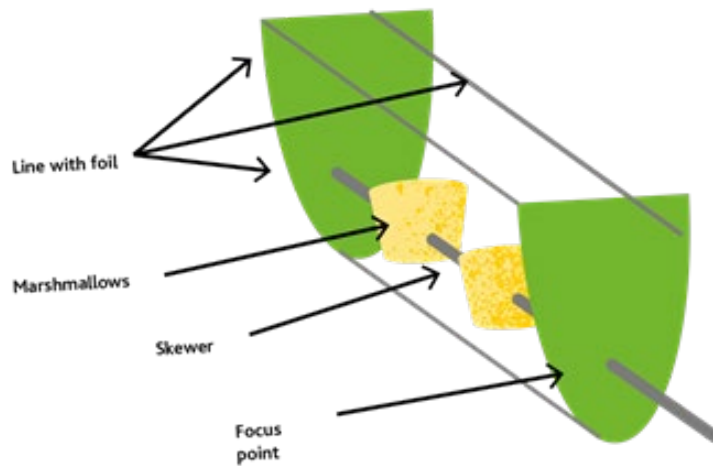

- It is important to explain the process that is happening, solar energy, in the form of sunlight is being converted into heat energy to heat and 'cook' the marshmallows.
- The principles of the process are;
 1. **Concentrating sunlight:** the reflective metal surface is reflecting the sunlight so that it is concentrated and the energy is stronger at the focus point where the skewer and marshmallows are located
 2. **Converting light energy to heat energy:** the interaction between the light energy and the receiver materials converts light to heat and this is called conduction
 3. **Trapping heat energy:** this heat energy is now being 'trapped' within the parabolic trough and as more light energy enters it will continue to be converted into heat energy, this process can be increased by covering the top of the parabolic oven with the transparent acrylic sheet.

- The parabolic solar oven lets the UV light rays in and then converts them to longer infrared light rays. Infrared radiation has the right energy to make water, fat and protein molecules in food vibrate vigorously and heat up.
- It is not the sun's heat that cooks the food, nor is it the outside ambient temperature (though this can affect the rate or time required to cook) but rather it is the sun's rays that are converted to heat energy that cook the food.

4. Final assessment activity (5 minutes)

- Once all the groups have completed the task and tested their ovens the teacher will decide which group's oven worked the best based on the temperature it achieved and / or the level in which their marshmallows were cooked.

Instructions for teachers:

Interesting facts about parabolas:

1. A parabola is plane curve which is mirror-symmetrical and is approximately U-shaped, the mathematical equation is $y^2 = 2px$ or $x^2 = 2py$
2. If you throw a ball, the trajectory it follows through the air is a parabola
- 3 Any ray of light that's parallel to the parabola's axis of symmetry will be reflected onto the focus point. That's why parabolas are used to focus torch or headlight beams and are also used in satellite dishes.

Differentiation Ideas:

Support: Make one model for students to copy prior to the session.

Challenge: Ask teams to also make ovens based around hemispheric end formers and compare their performance. Discuss why the parabola works better: the shape focuses the light onto the axis, where the marshmallows are positioned. A hemisphere can't focus the light in the same way.

Additional prompts for participating students:

- Use the foil shiny side out and take care not to wrinkle it when gluing to the card.
- Don't forget to coat the two end former parabolas in foil as well.
- It's important that as much light as possible can get below the marshmallows, which should be in small enough pieces so that they don't touch the foil trough.
- Angle the ovens so that they point at the sun or the lamp being used.

- The red dot on the parabola template is the focus point – the axis on which the skewer will go and on which the marshmallows will need to be.
- Light needs to reflect off the parabola and trough lining onto the marshmallows and that's vital for an efficient cooking process.

Other Comments:

Extension Ideas:

- Students could research and build other forms of solar ovens.
- Students can research 'rocket' stoves, which drastically reduce the smoke produced by burning wood. Why are rocket stoves important for people's health in less economically developed countries?



Overview of the Educational Materials and Resources



Implementation of Workshops & Thematic School Days

During the implementation phase of the project, teachers and students were involved in the making process as co-designers to produce educational materials that can enrich the teaching and learning experience. A variety of educational materials and resources for STEAM related thematic school days and workshops have been produced, which are directly linked with the implementation phase of the project. These artefacts (i.e. videos, images, posters games, worksheets, competitions, group activities, songs, podcasts etc.) can be introduced as OERs in the mainstream of primary and secondary curricula to support STEAM education practices. Each material and resource are presented in a tabular form accompanied by 4 subtopics namely: Title, Type, Evidence, and Content.



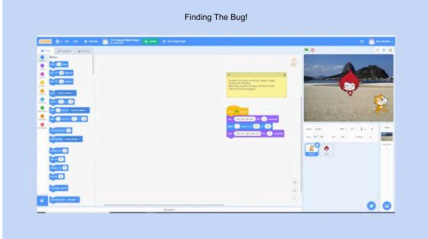
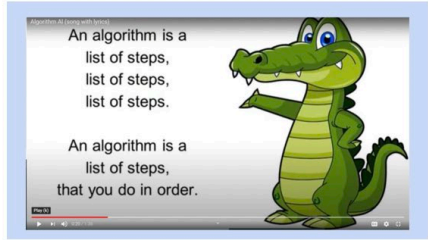

Title	"Introduction to Coding"
Type	<input type="checkbox"/> Workshop Plan <input type="checkbox"/> Thematic School Day Plan <input checked="" type="checkbox"/> Poster <input type="checkbox"/> Video <input type="checkbox"/> Other
Evidence (e.g. video or image)	Poster (PDF file)
Content	 <p>Εισαγωγή Ο προγραμματισμός έχει αναγνωριστεί ως μια δεξιότητα που απαιτεί από τους χρήστες να χρησιμοποιούν υπολογιστικά εργαλεία για να αντιμετωπίσουν πραγματικά προβλήματα του 21ου αιώνα. Οι δεξιότητες του 21ου αιώνα στον τομέα των ΤΠΕ περιλαμβάνουν και την ικανότητα του προγραμματισμού, η οποία μάλλον είναι μια δεξιότητα που μπορεί να αποκτηθεί στα χρόνια του γυμνασίου ή ακόμη και νωρίτερα. Η ιδέα του προγραμματισμού από τα παιδιά, δηλαδή η ικανότητα των παιδιών να γράφουν κώδικα σε υπολογιστικά προγράμματα, είναι ένα θέμα που συζητείται στον τομέα της εκπαιδευτικής τεχνολογίας.</p> <p>Στόχοι του μαθήματος Με το τέλος του μαθήματος οι μαθητές πρέπει να είναι ικανοί να: <input type="checkbox"/> Κατανοήσουν τι είναι προγραμματισμός και αλγόριθμος μέσω από συγκεκριμένα παραδείγματα. <input type="checkbox"/> Προγραμματίσουν ρομπότ εδάφους (Pro – Bot), ώστε να επιλύσουν διάφορα προβλήματα. <input type="checkbox"/> Χρησιμοποιούν λογισμικά προγραμματισμού, ώστε να επιλύσουν διάφορες αποστολές. Οι μαθητές δούλεψαν σε τρεις σταθμούς. Σε κάθε σταθμό είχαν διαφορετική αποστολή.</p> <p>Σταθμός 1: Προγραμματισμός μέσω της ιστοσελίδας code.org Στον σταθμό αυτό οι μαθητές εισάγονται στην έννοια του προγραμματισμού μέσω μιας σειράς μαθημάτων διαβαθμισμένων επιπέδων δυσκολίας. Η ιστοσελίδα έχει σκοπό να εισάγει τους μαθητές στις βασικές έννοιες της επιστήμης της πληροφορικής.</p> <p>Σταθμός 2: Προγραμματισμός του ρομπότ εδάφους (Pro – Bot) Το Pro – Bot είναι ένα ρομπότ τύπου χελώνας, το οποίο κινείται στο έδαφος με τη βοήθεια δύο τροχών. Στήριζεται στη γλώσσα προγραμματισμού Logo, η οποία είναι απλή και εύκολη. Επίσης μπορεί να δεχτεί μαρκάδωρο για σχεδιασμό γεωμετρικών σχημάτων, μοτίβων κ.α.). Οι μαθητές με τη χρήση του Pro – Bot προστάθηκαν να φέρουν εις πέρας τις αποστολές που τους είχαν τεθεί, οδηγώντας το αυτοκίνητο σε συγκεκριμένα σημεία ή ζωγραφίζοντας διάφορα γεωμετρικά μοτίβα.</p> <p>Σταθμός 3: Προγραμματισμός μέσω tablet, χρησιμοποιώντας το εφαρμογίδιο A.L.E.X. Η εφαρμογή A.L.E.X. είναι ένα διδακταστικό παιχνίδι, κατάλληλο για εγκατάσταση σε φορητές συσκευές (βαθ ή Android tablet). Έχει τη δυναμική να προσέει μμετα στον αρχικό μαθηματικό εννοιών και διαδικαστικών. Παρέχει την ευκαιρία στον μαθητή να σκεφτεί λογικά και να εκπονήσει στο μυαλό του σχέδια, καθώς προγραμματίζει το ρομπότ A.L.E.X. με μια σειρά εντολών. Στόχος είναι το καθοδηγούμενο ρομπότ να μπορεί να διέλθει κάθε στάδιο του παιχνιδιού από την αφετηρία μέχρι το τέλος. Οι χρήστες μπορούν επίσης να «κατασκευάσουν» τα δικά τους στάδια, τα οποία θα ήθελαν ο A.L.E.X. να ακολουθήσει.</p> <p>Φωτογραφικό υλικό</p> <p>Σχόλια των μαθητών για το πρόγραμμα</p> <ul style="list-style-type: none"> • Το μάθημα με τα tablets ήταν πολύ διδακταστικό...Ελπίζω στο μέλλον να το ξανακάνουμε! – Ρομπέρτος • Ήταν πολύ ενδιαφέρον που προγραμματίσαμε το αυτοκίνητο και αυτό εκτελούσε τις εντολές μας – Νικόλαος • Το μάθημα με εντυπωσίασε. Εμείς να προγραμματίζω και να βρίσκω λύσεις σε δύσκολα προβλήματα. Αυτό πιστεύω θα με βοηθήσει στο μέλλον – Ελένη • Απολαύσα το μάθημα! Ελπίζω να το ξανακάνω – Κατερίνα • Το μάθημα ήταν συναρταστικό! Μου έφερε τα σπέρμα του προγραμματισμού το ρομπότ να ζωγραφίζει διάφορα γεωμετρικά μοτίβα –Θεανώ
Title	'Exploring Geometric Solids'
Type	<input type="checkbox"/> Workshop Plan

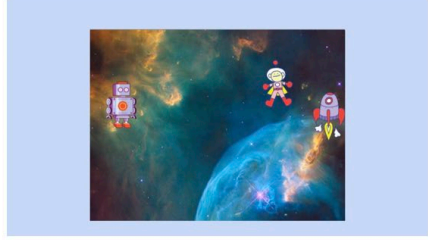
	<input type="checkbox"/> Thematic School Day Plan <input type="checkbox"/> Poster <input checked="" type="checkbox"/> Video <input type="checkbox"/> Other
Evidence (e.g. video or image)	Insert link of YouTube video here (geometric_solids.mp4)
Content	<p>geometric_solids.mp4</p> <p>Exploring Geometric Solids</p> <p>0:01 / 3:17</p>
Title	Activity on robotics
Type	<input checked="" type="checkbox"/> Workshop Plan <input type="checkbox"/> Thematic School Day Plan <input type="checkbox"/> Poster <input type="checkbox"/> Video <input type="checkbox"/> Other

<p>Evidence (e.g. video or image)</p>	<p>Image (Total 6: Fix The Bug 1-3.jpg, Scratch Project.jpg, Demonstrating Scratch Project.jpg, Algorithm AI.jpg,)</p>
<p>Content</p>	<div style="border: 1px solid purple; padding: 10px;"> <p>Group 1:</p> <p>What they did – At the beginning of the session, the teacher introduced the STEAM lesson plan on robotics, and engaged all pupils in a warm-up activity where pupils were given different commands that they had to act out. This was a short icebreaker that gave pupils an introduction to how commands work in practice. Each pupil had the opportunity to take turns and give commands to other pupils. Commands like 'raise right arm' and 'pat head' and 'point to nose' were given, and all pupils had to follow the commands. This showed students how commands can lead to responses and actions.</p> <p>What they learned – After this ice breaker activity, pupils then completed some simple challenges 'Finding the Bug' and 'Fixing the Bug' to further develop their coding skills, through simple techniques and activities. To introduce the pupils to coding, the Teacher first played the 'Algorithm AI' song, and the pupils sang along.</p> <p>What they enjoyed – The pupils engaged very well with the coding activities and will collaborating to 'Find' and 'Fix' the 'Bug'. They enjoyed the challenge in this activity.</p> </div> <div style="display: flex; justify-content: space-around; margin-top: 10px;">     </div>
<p>Title</p>	<p>“WebQuest activity for Ada Lovelac”</p>
<p>Type</p>	<p> <input type="checkbox"/> Workshop Plan <input type="checkbox"/> Thematic School Day Plan <input checked="" type="checkbox"/> Poster <input type="checkbox"/> Video <input type="checkbox"/> Other </p>

<p>Evidence (e.g. video or image)</p>	<p>Images (AdaLovelace 1-4.jpeg)</p>
<p>Content</p>	<div style="border: 1px solid #00a0e3; padding: 10px;"> <p>Group 2:</p> <p>What they did – As all schools in our region are currently closed due to level 5 COVID-19 restrictions, it was decided that the WebQuest activity for Ada Lovelace would be tested as part of a home school activity. For this activity, the school provided students with access to the WebQuest and an iPad, and the parents were instructed on how to complete the task included in the WebQuest.</p> <p>What they learned – The pupils who participated in this home-schooling testing enjoyed the experience. Their parents helped them to complete the WebQuest about Ada Lovelace and women in STEAM, and the pupils learned a lot about female role models in this sector. The parents also fed-back that this was an enjoyable experience, as the parents and pupils could work together to follow the links in the WebQuest and complete the task together – learning along the way.</p> <p>What they enjoyed – The pupils enjoyed using technology to support their learning and having a challenge or puzzle to solve with their parents. Through this testing, the feedback was very positive, with Teachers in the local school suggesting that the format of WebQuests could be adapted to home-schooling in the future, should the school closures due to COVID persist.</p> </div>
<p>Title Potential Social Impact of Solar Cooking</p>	
<p>Type</p>	<p><input checked="" type="checkbox"/> Workshop Plan</p> <p><input type="checkbox"/> Thematic School Day Plan</p> <p><input type="checkbox"/> Poster</p> <p><input type="checkbox"/> Video</p>

	<input type="checkbox"/> Other
Evidence (e.g. video or image)	  <p>Images within experimental workshop plan (STEAMitUp_IO1_Workshop plan - Solar Ovens.pdf)</p>
Content	See Experimental workshop plan

Group 1:

What they did – At the beginning of the session, the teacher introduced the STEAM lesson plan on robotics, and engaged all pupils in a warm-up activity where pupils were given different commands that they had to act out. This was a short icebreaker that gave pupils an introduction to how commands work in practice. Each pupil had the opportunity to take turns and give commands to other pupils. Commands like 'raise right arm' and 'pat head' and 'point to nose' were given, and all pupils had to follow the commands. This showed students how commands can lead to responses and actions.

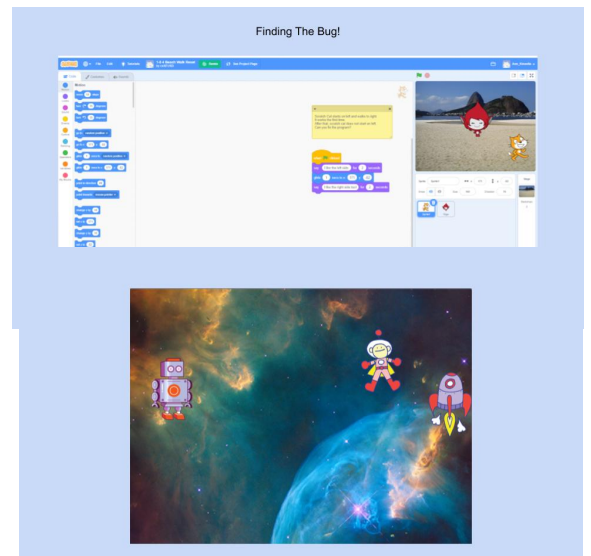

Group 2:

What they did – As all schools in our region are currently closed due to level 5 COVID-19 restrictions, it was decided that the WebQuest activity for Ada Lovelace would be tested as part of a home school activity. For this activity, the school provided students with access to the WebQuest and an iPad, and the parents were instructed on how to complete the task included in the WebQuest.

What they learned – The pupils who participated in this home-schooling testing enjoyed the experience. Their parents helped them to complete the WebQuest about Ada Lovelace and women in STEAM, and the pupils learned a lot about female role models in this sector. The parents also fed-back that this was an enjoyable experience, as the parents and pupils could work together to follow the links in the WebQuest and complete the task together – learning along the way.

What they enjoyed – The pupils enjoyed using technology to support their learning and having a challenge or puzzle to solve with their parents. Through this testing, the feedback was very positive, with Teachers in the local school suggesting that the format of WebQuests could be adapted to home-schooling in the future, should the school closures due to COVID persist.

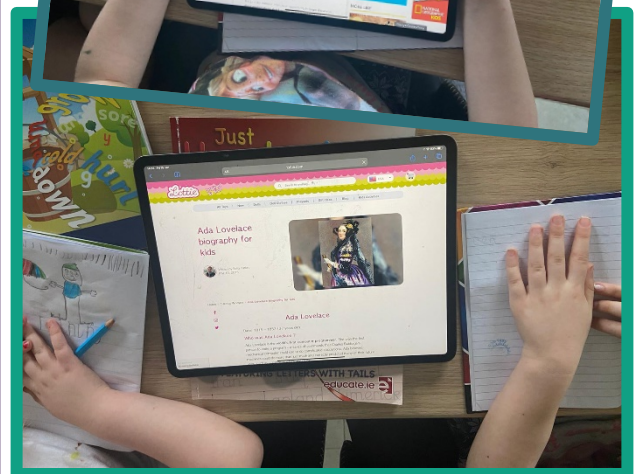
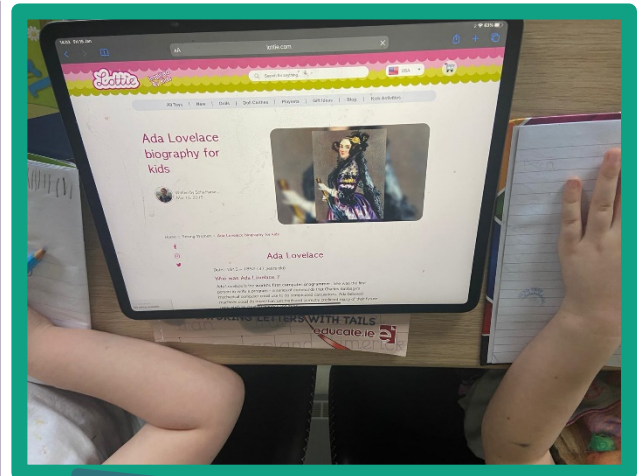



Title	Potential Social Impact of Solar Cooking
Type	<input checked="" type="checkbox"/> Workshop Plan <input type="checkbox"/> Thematic School Day Plan <input checked="" type="checkbox"/> Poster(s) <input type="checkbox"/> Video <input type="checkbox"/> Other
Evidence (e.g. video or image)	Five Posters
Content	See Experimental Workshop

Workshop Overview:

- A more detailed look at the concept of solar ovens and the potential impacts on the global population and energy usage. Groups will build a more advanced version of a solar oven to heat water. This is to replicate the possible way in which water sources can be made safer for consumption in areas where energy sources are scarce or how to conserve energy for warming water for hygienic purposes.

Objectives:

Upon completion of this workshop students will;

- Understand that there are nearly a billion people (13% of the global population) that do not have access to a stable source of electricity and 3 billion (40% of global population) who do not have access to clean fuels for cooking. Understand there are more than 3 million premature deaths each year due to cooking pollution
- Research the activities undertaken by people to find fuels sources and the dangers associated with this process and the use of such fuels
- Consider the impact of the human activities on the environment and society
- Build a basic solar oven using limited resources
- Attempt to use the solar oven to heat water for either safe consumption or for use for hygiene purposes
- Complete various calculations and extrapolate data values

- Apply critical thinking to solving the cooking and heating related problems in the world
- Experience team building and real-world problem solving.

Material / resources:

1. Medium sized cardboard boxes or shoe boxes
2. Rolls of aluminium foil
3. Sheets of black paper / card or black oven tray that will fit within the boxes
4. Sticky tape and / or glue
5. Scissors
6. Digital thermometers (one for measuring ambient and one for water temperatures)
7. Water source
8. Measuring cylinders
9. Black liquid container or small cooking pan
10. Insulated gloves for handling containers carrying hot liquids
11. Graph paper, timer / stopwatch and a pencil
12. **If possible, sheets of polystyrene of the same size as the size of the sides of the box to increase insulation and help to keep more heat inside the oven**
13. **Sheets of Perspex, Plexiglas, actual glass and mirrors if working with older students or making a more advanced solar oven**
- 14 **If attempting to undertake this activity on a day where there is little or no sun light then you may need to use halogen lamps to recreate the light and heat necessary to warm the solar ovens**

****This activity works best on a sunny or partially sunny day****

Workshop Activities:

5. Introduction and context

The problem (Teacher delivery):

- More than 3 billion people in the world do not have sufficient energy for cooking and heating and they often have to cut down and burn trees to cook or to pasteurize water to make it safe for drinking - <https://ourworldindata.org/energy-access>
- There are more than 3 million premature deaths each year due to open-fire cooking pollution - <https://www.who.int/news-room/fact-sheets/detail/household-air-pollution-and-health>
- Cutting down trees for cooking and heating accelerates deforestation. Burning fuels indoor for cooking and heating represents a significant health problem. Spending time looking for trees or spending money for buying cooking and heating fuels also limits the resources for social development.

- For some context to these problems please watch:
<https://www.youtube.com/watch?v=x6AGXne27kY> and / or
<https://www.youtube.com/watch?v=EoAfXfparNY>

Workshop discussion (small group breakout activity):

- Participants to work in small groups (3-4 people per group)
- Ask the groups to spend some time thinking about the different types of alternative cooking fuels used where electricity is unavailable (e.g. Wood, Kerosene, Charcoal, Coal and Dung)
- Next, the groups should discuss what activities and problems could be associated with sourcing these different types of energy sources (e.g. mining, deforestation, risk of fire, diseases, risk of injury or even death)
- Finally, the groups should brainstorm some ideas on how this problem could be addressed and identify some potential solutions for safer sustainable energy sources.

One potential solution (Teacher delivery):

- Introduce the concept of community-oriented solar cooking technology and how developing user-friendly solar ovens can help to solve the environmental, health, and social development issues linked to this problem. Please watch the following for more context -
<https://www.youtube.com/watch?v=Ofn7jqPDTeY&t=45s>

Important information (Teacher delivery):

- ***Contrary to what many people believe, it is not necessary to boil water to make it safe to drink. Heating water to 65° C (149° F) for 6 minutes, or to a higher temperature for a shorter time, will kill all germs, viruses, and parasites. This process is called pasteurization*.**

6. Building a simple solar oven (practical workshop activity with Teacher guidance):

- The groups will now engineer and produce a simple DIY solar oven.
- Keep the participants in the groups assigned earlier and provide them with all the necessary materials mentioned in materials / resources section above.
- The groups start by lining all the inner areas of their cardboard boxes (including the folding over flaps or lid) with aluminium foil. This can be done using either glue or sticky tape (see example images below).



- **If using polystyrene sheets for added insulation within the box, then groups should cover the polystyrene with the aluminium foil first and then place them inside the box to cover all four internal sides*.*
- **If using shoe boxes, then the groups will have to cut into the lid to create an opening flap as in the images below*.*

Cut here, 1 inch from the edge of the box top.

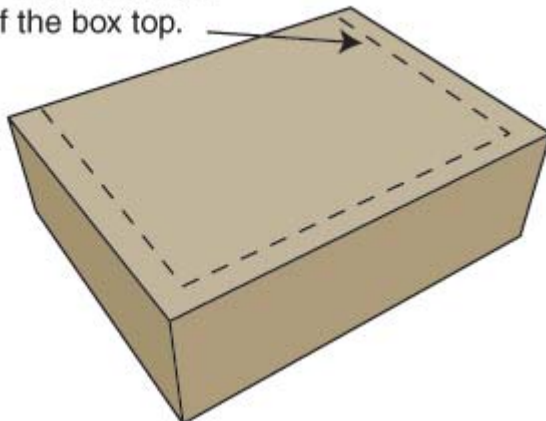

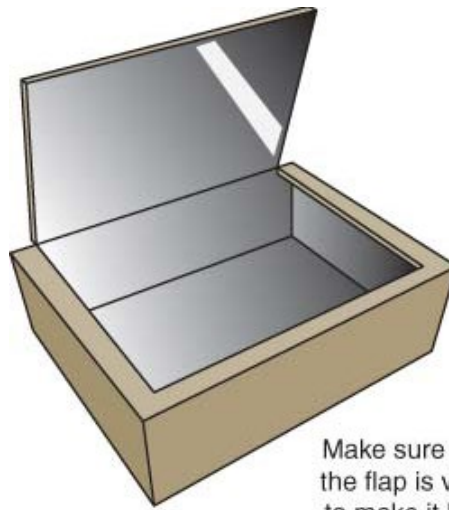

Make sure the foil inside the flap is very smooth, to make it like a mirror.

- The groups should then cover the inside base of the box with either the black paper / card or by placing a black oven tray within the box to increase the radiating effect within the oven.
- ****If the groups have access to Perspex, Plexiglas or glass sheets then these can be added as a covering over the box to help to keep the heat within the box and improve the heating process (see diagrams below)*.***

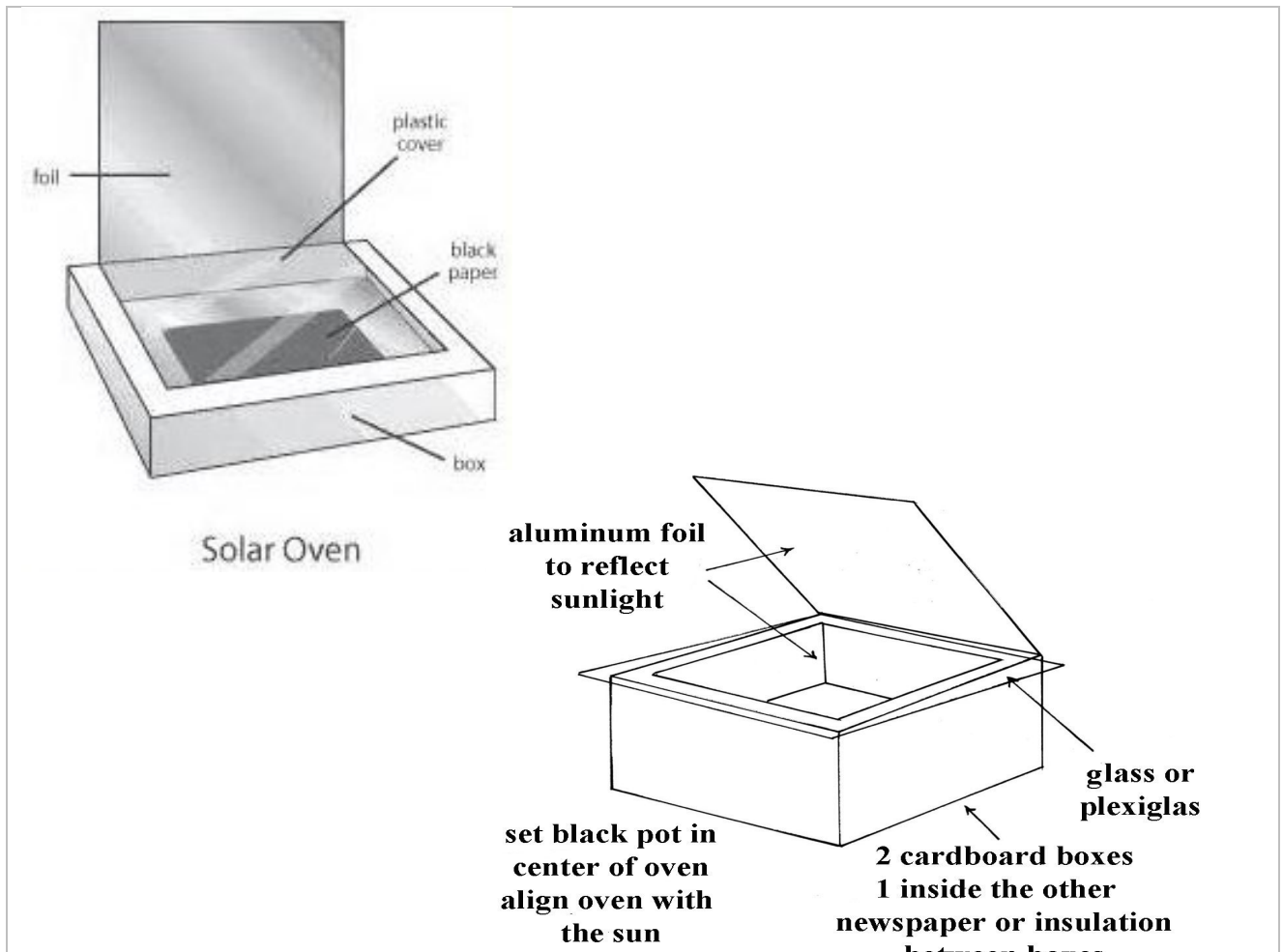

Solar Oven

aluminum foil to reflect sunlight

set black pot in center of oven align oven with the sun

2 cardboard boxes 1 inside the other newspaper or insulation between boxes

glass or plexiglas

There are several ways in which the groups could make a solar oven, the above is just one of these ways, here are some additional resources to guide the production process;

1. <https://www.greenmatch.co.uk/blog/2016/08/build-your-own-solar-oven-in-5-steps>
2. <https://www.fix.com/blog/solar-cooking/>
3. <https://sciencing.com/make-shoebox-solar-oven-5240773.html>
4. <https://www.dummies.com/home-garden/green-living/energy-sources/how-to-make-a-solar-oven/>
5. <https://www.wikihow.com/Make-and-Use-a-Solar-Oven>

Video guides to making basic solar ovens;

1. <https://www.youtube.com/watch?v=v5CdNH3sQT0>

2. <https://www.youtube.com/watch?v=gofh1vy2XzI>
3. <https://www.youtube.com/watch?v=xXxrX0JyKa8>
4. https://www.youtube.com/watch?v=wGfgjXJ_rE (aimed at a younger student cohort)
5. <https://www.youtube.com/watch?v=tDB3zP9MEZc> (more advance solar ovens using wooden box, glass and mirrors)

7. Use your solar oven to heat water (group activity with Teacher guidance)

- The groups will now try to use the DIY solar ovens to heat a container of water.
- Ideally, the groups will allow the solar ovens to heat up first, they should place a thermometer into the ovens to monitor the ambient temperature within.
- Place the ovens in direct sunlight with the reflective surfaces facing the sun, this could be done outside or inside next to a window facing the sun.
- ****If you are attempting to undertake this workshop on an overcast day or during the winter where temperatures will not reach sufficient levels, then halogen lamps can be used to recreate the light and heat generated by sunlight*.***
- The groups should begin to monitor and record the ambient temperature within the ovens at regular 2 minute intervals. They should record their figures on the graph paper provided (with the horizontal axis recording time and the vertical axis recording temperature as shown below).

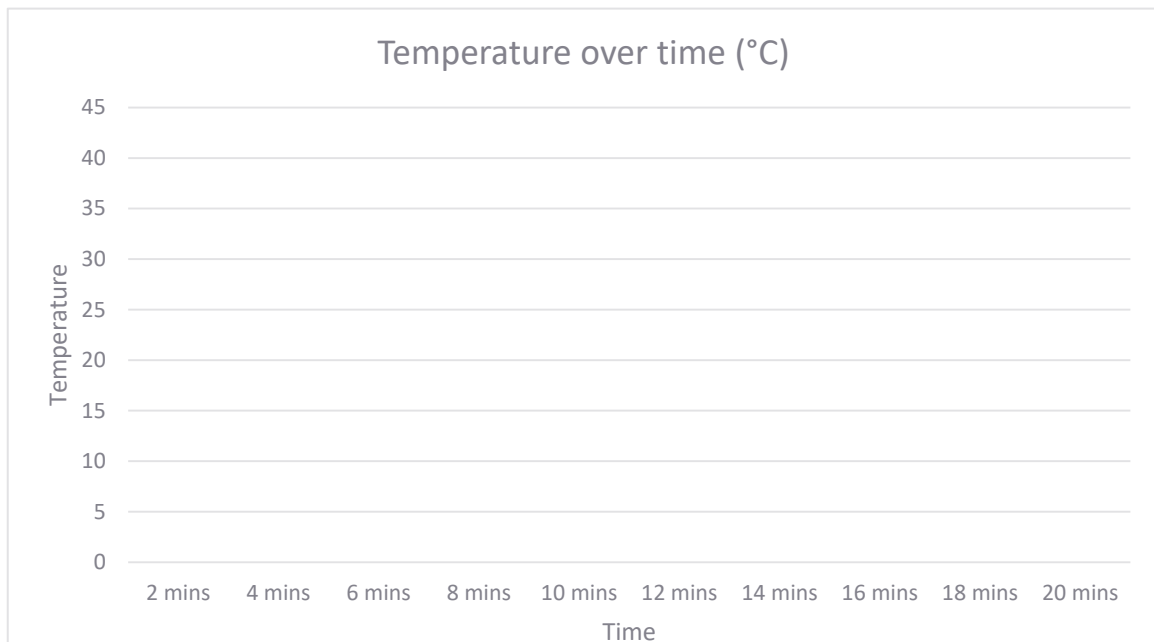

- Once the ambient temperature within the solar oven reaches 30°C / 86°F then groups should add their liquid containers / cooking pans containing 300ml of water.
- The groups should place their ovens in the optimal position to absorb the most amount of light and heat possible to ensure efficiency (please see the diagrams provided).

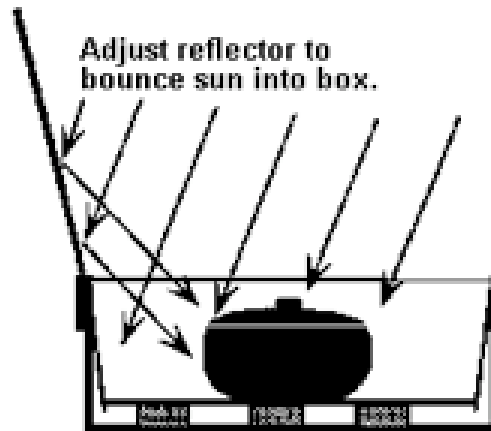

Sunlight heats the container and solar absorber plate. The absorber plate moves the heat to the water or food.

The absorber plate must be supported above the box bottom to prevent heat loss.

- Groups should now place a liquid thermometer into the container of water and again begin to monitor the temperature reading at regular 2-minute intervals as they did with the ambient temperature within the ovens.

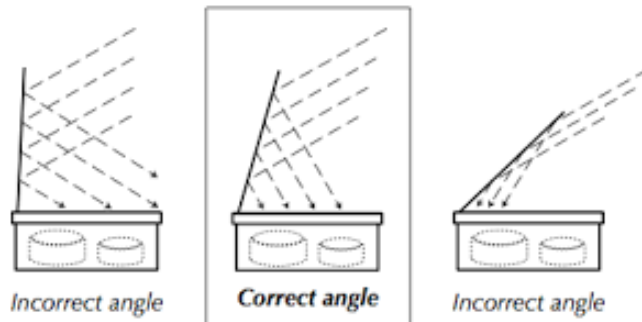

- These figures can be recorded on the same graph as used for the previous records, however it will likely take longer to heat the water to the sufficient temperature than it took to heat the solar ovens to 30°C (please see the diagram below for an example).
- If the aim of the activity is to pasteurize water for safer consumption, then groups are

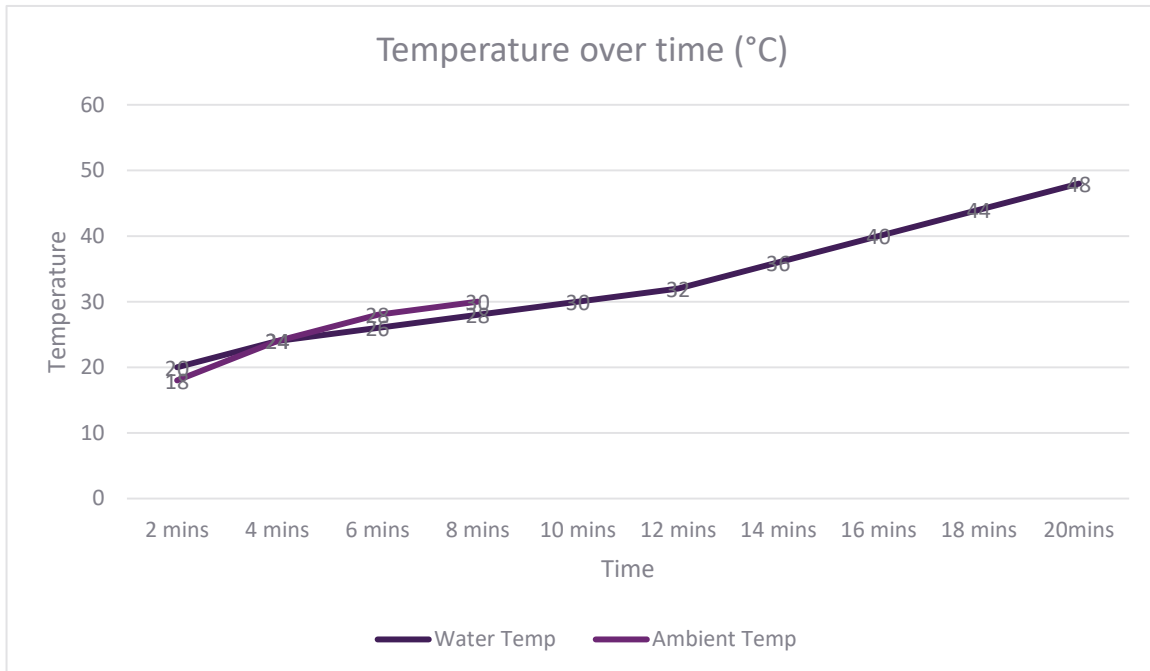

aiming to heat the water to a temperature of 65°C for a 6 minute period. If the aim is to show how water can be heated using solar energy for hygiene purposes then a temperature of 45 – 50°C will be sufficient (this is around the temperature of warm water from a standard household tap).

- ****It is worth noting that the rate in which the solar ovens will heat the water will vary dramatically depending on the temperatures achieved within the ovens. If the experiment is taking place on a hot sunny day in a country with a warm climate then the process will be far more effective and quicker than if taking place on a day with limited sunlight in a more temperate climate. The use of Halogen lamps will help to speed up the heating process if required and available*.***
- ****it is also important to consider that if the conditions are extremely warm then the process of heating the water will also cause evaporation of the water, if this is the case then the groups may have to start with a larger volume of water (e.g. 500ml instead of 300ml) in order to factor in the effect of evaporation. This issue could also be addressed by covering the water container with a lid to reduce water loss through evaporation*.***

There is a lot of information available regarding the pasteurization of water;

1. <http://www.solarcooking.org/pasteurization/metcalf.htm> (information about solar water pasteurization)
2. https://sswm.info/sites/default/files/reference_attachments/ANDREATA%20007%20A%20Summary%20of%20Water%20Pasteurization%20Techniques.pdf (detailed research on the pasteurization of water)
3. https://solarcooking.fandom.com/wiki/Water_pasteurization (more information regarding water pasteurization)
4. <https://www.youtube.com/watch?v=9KVhjn40ck> (more specifics behind the idea of pasteurizing water using solar ovens)

8. *Do the Math....potential scalability (group activity with Teacher guidance)*

- So, the groups have made their solar ovens and demonstrated how it is possible to warm water using the power of solar energy. Now, they will investigate how this process could work on a larger scale to help address some of the issues outlined at the beginning of the workshop.
- From the graphs each group created when recording the ambient and water temperatures within their solar ovens, there should be some useful data that can be extrapolated.
- Each group should now use their graphs to identify the following data;
 1. Calculate the time needed to pasteurize a cup of water (300ml)
 2. Calculate the volume of water that could be pasteurized in 1 hour
 3. Calculate the volume of water that could be pasteurized if there were 12 hours of sunlight in a day
 4. Finally, calculate the volume of water that could be pasteurized in a month if there were 20 sunny days.

Different Measures of Volume

10 millilitres (ml)	=	1 centilitre (cl)
100 millilitres	=	10 centilitres / 1 decilitre (dl)
1000 millilitres	=	1 litre (L)
10 litres	=	1 dekalitre (dal)
100 litres	=	10 dekalitres
1000 litres	=	1 kilolitre (kl)

- ****Each group should have slightly different figures as they will be extrapolated via the data gained from their own individual solar ovens*.***

9. *In conclusion.....what have we learned? (whole class discussion and debrief)*

- Hopefully, this workshop has been fun and informative for the participants and it has opened their eyes to a real global issue.
- They should now be able to reflect on the following;
 1. How a large percentage of the global population have no access to a stable source of energy
 2. How millions of unnecessary premature deaths could be avoided if alternative, safer and more sustainable forms of cooking / heating water could be implemented
 3. How, using limited resources, you can sometimes overcome complex problems
 4. How they can utilise Science, Design Technology and Math in everyday situations
 5. How they can extrapolate data values from a data source.

Additional information for workshop delivery:

- There are other types of solar ovens that can be used for different purposes. This workshop has focused on using a solar oven to heat water, however they can be, and are used all over the world to cook food without using any energy source other than sunlight.
- The potential positive impacts of using solar ovens for providing a sustainable source of energy and reducing the negative impact of deforestation and pollution from

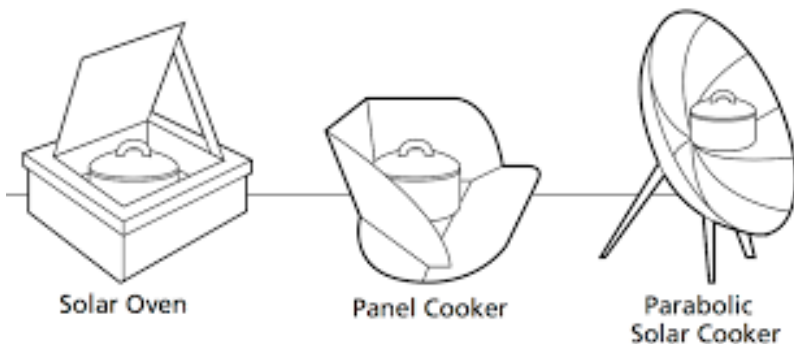

- using other cooking methods is yet to be fully explored.

- Different types of solar ovens have different attributes that make them suitable for different purposes, the chart below gives an overview.

SOLAR COOKERS COMPARED

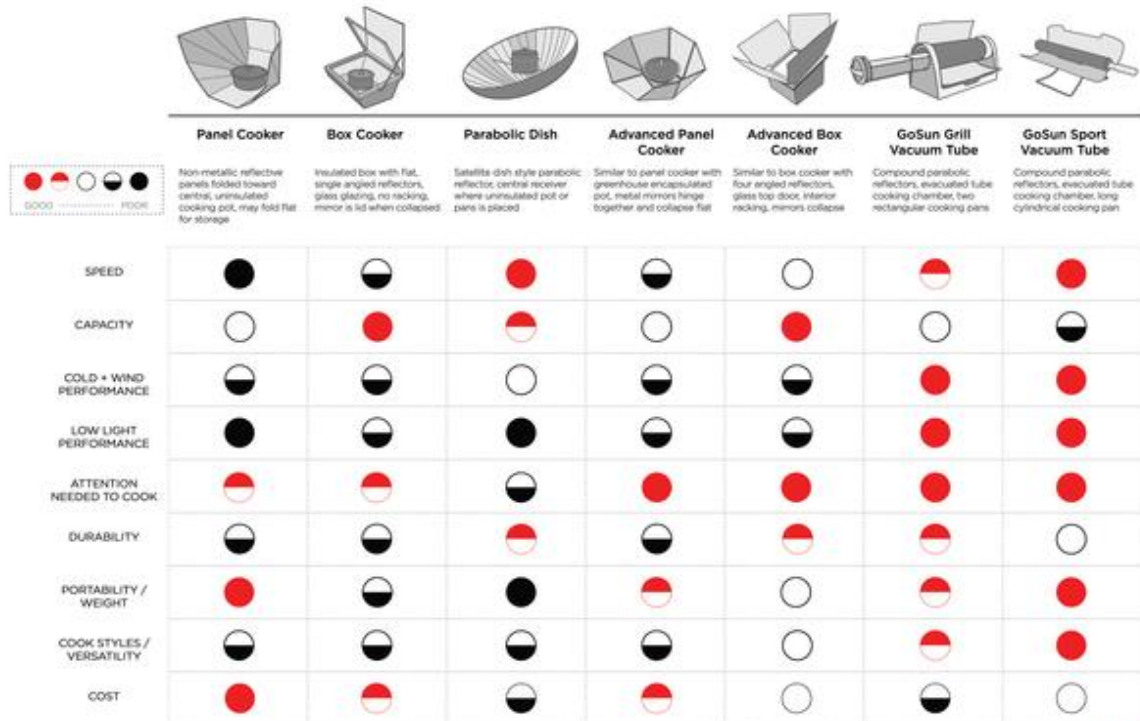

All Rights Reserved, GoSun Stove, 2016

Other useful references:

1. <https://ourworldindata.org/energy-access> (information regarding access to energy sources globally)
2. <https://www.who.int/news-room/fact-sheets/detail/household-air-pollution-and-health> (World Health Organisation Data on air pollution caused by cooking)
3. <https://gosun.co/blogs/news/top-solar-cookers-compared> (more information about different types of solar ovens)
4. <https://www.thecalculatorsite.com/conversions/liquidvolume.php> (liquid volume conversions)

SOLAR OVEN: COMPARATIVE COSTS OF COOKING

Estimates for cooking one large casserole

APPLIANCE	TEMP	TIME NEEDED	ENERGY USED	COST
Electric Oven	350°F	1 hour	2.0 kWh	\$ 0.16
Convection Oven	325°F	45 minutes	1.39 kWh	\$ 0.11
Gas Oven	350°F	1 hour	.112 therm	\$ 0.07
Electric Frying Pan	420°F	1 hour	.9 kWh	\$ 0.07
Toaster Oven	425°F	50 minutes	.95 kWh	\$ 0.08
Crockpot	200°F	7 hours	.7 kWh	\$ 0.06
Microwave	HIGH	15 minutes	.36 kWh	\$ 0.03
Solar Oven	275°F	4 hours	solar	Free!



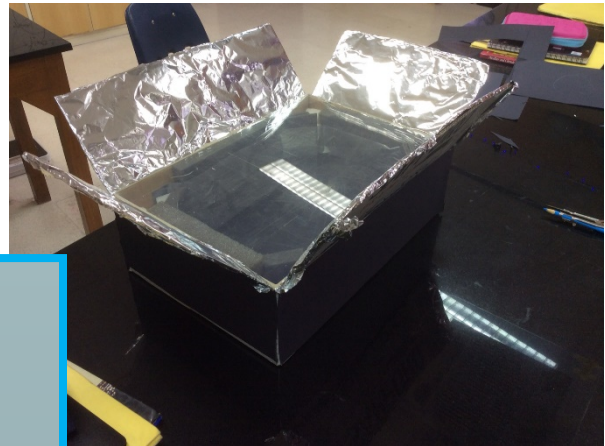

Group 1:

What we did – In the morning we had to listen to a presentation on the STEAM project and the subjects. We then used some basic resources and templates to make a skewer cooker that we had to try to use to melt marshmallows. We then spent the rest of the day making a cardboard box solar cooker that we had to try to heat water in. We then spent some time discussing the activities and thinking about the different skills we were using.

What we learned – We learned how to work as a team to build things using only the items we were given. We learned about solar energy and how it can be used to cook or heat things if the weather is right. After we had finished all the activities, we talked about what we had done and realised that we had learned lots of different skills, we had used Maths, Science and Engineering.

What we enjoyed – Our group had lots of fun even though our cookers were not very

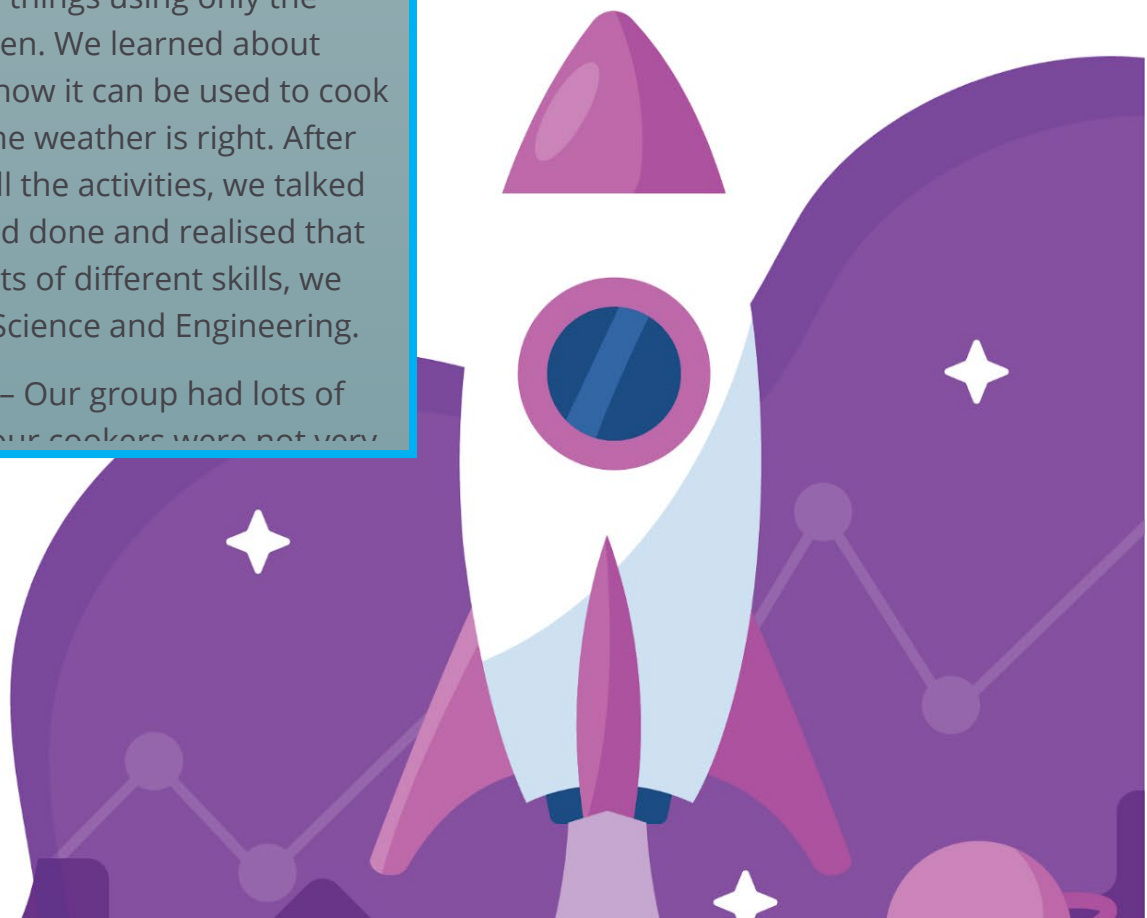



Group 2:

Our group really enjoyed the STEAM day and all the experiments we did. It is not often we get to spend a whole day making things and trying them out. Our groups worked well, and everyone helped each other to complete all the tasks.

We learned a lot about the world and how lots of people do not have clean water or electricity. We learned about how solar energy works and how you can use it to cook food or warm water if the temperature is high enough. We also learned about parabolas, energy conversion and graphs.

Our experiments work quite well but we found it hard to get our oven warm enough to get the water to the temperature we needed to. It was not a sunny day so we had to use a lamp to generate light and heat, but it was not strong enough.



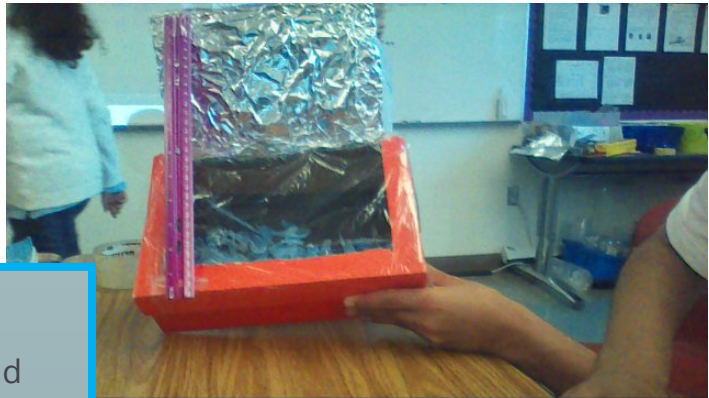

Group 3:

This STEAM day was a lot of fun and we learned a lot from the lessons. We spent lots of time talking in our group and trying to make our solar ovens together. Our group worked well but we all had different ideas how to do things and that sometimes made things harder.

It was interesting to learn about people in other countries who don't have access to water and power and we didn't know how big a problem it was. Making the different kinds of solar ovens was fun and it was interesting to see how they are supposed to work. The weather was too cold to use them outside, so we had to use lamps to melt the

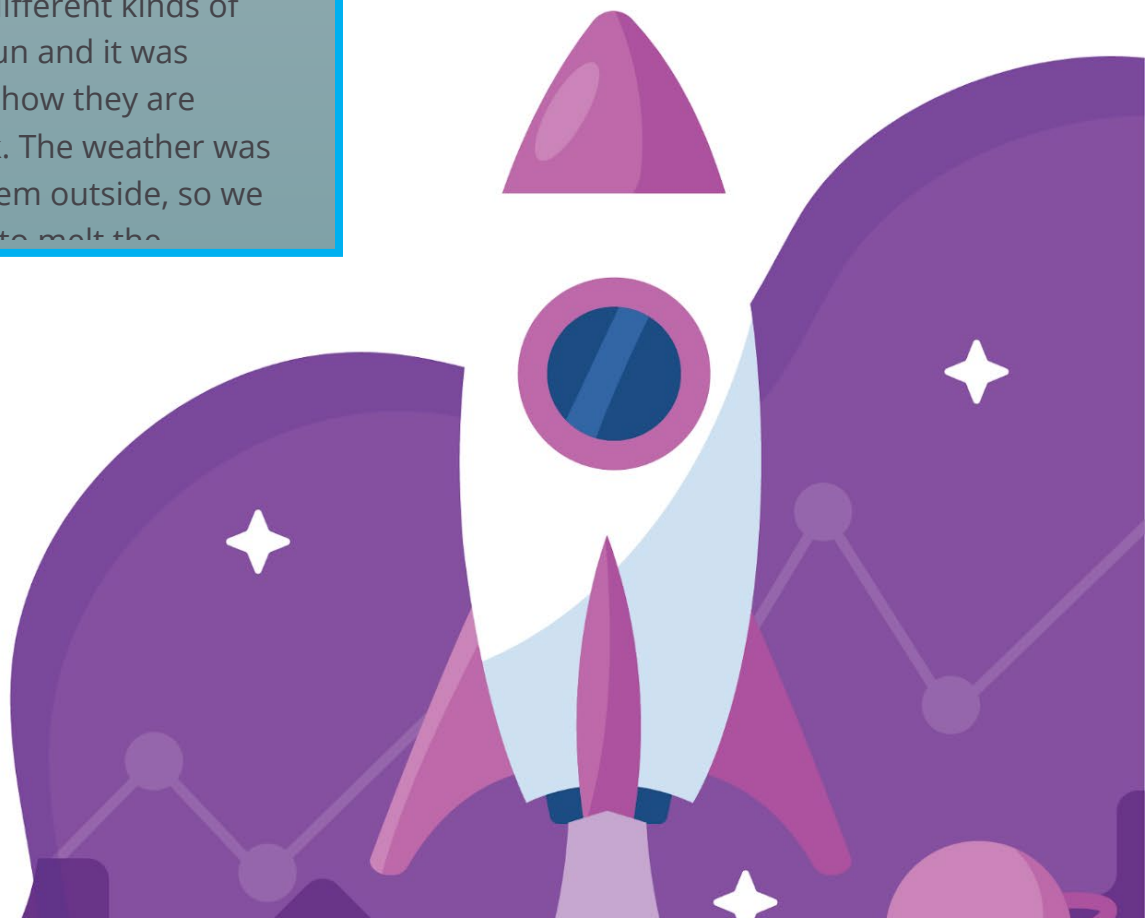



Group 4:

The STEAM activity day was very interesting and we all really enjoyed it. We learnt a lot of different things through the day including how solar energy works and how you can use the sun's energy to heat things. We had to use some materials to make some different types of solar ovens to cook marshmallows and to try to heat some water and record the temperatures.

We were split into 4 groups and each group had to work together to do all the tasks, this was fun as it made us all a bit competitive against each other.

We learned about how lots of people in the world do not have running water or electricity and have to find other ways to cook or wash. We learnt about how shapes can focus light energy and change it into heat energy. We learnt about how to make water safer to use for cooking or drinking and how to make a solar oven using simple household materials.

www.steamitup.com

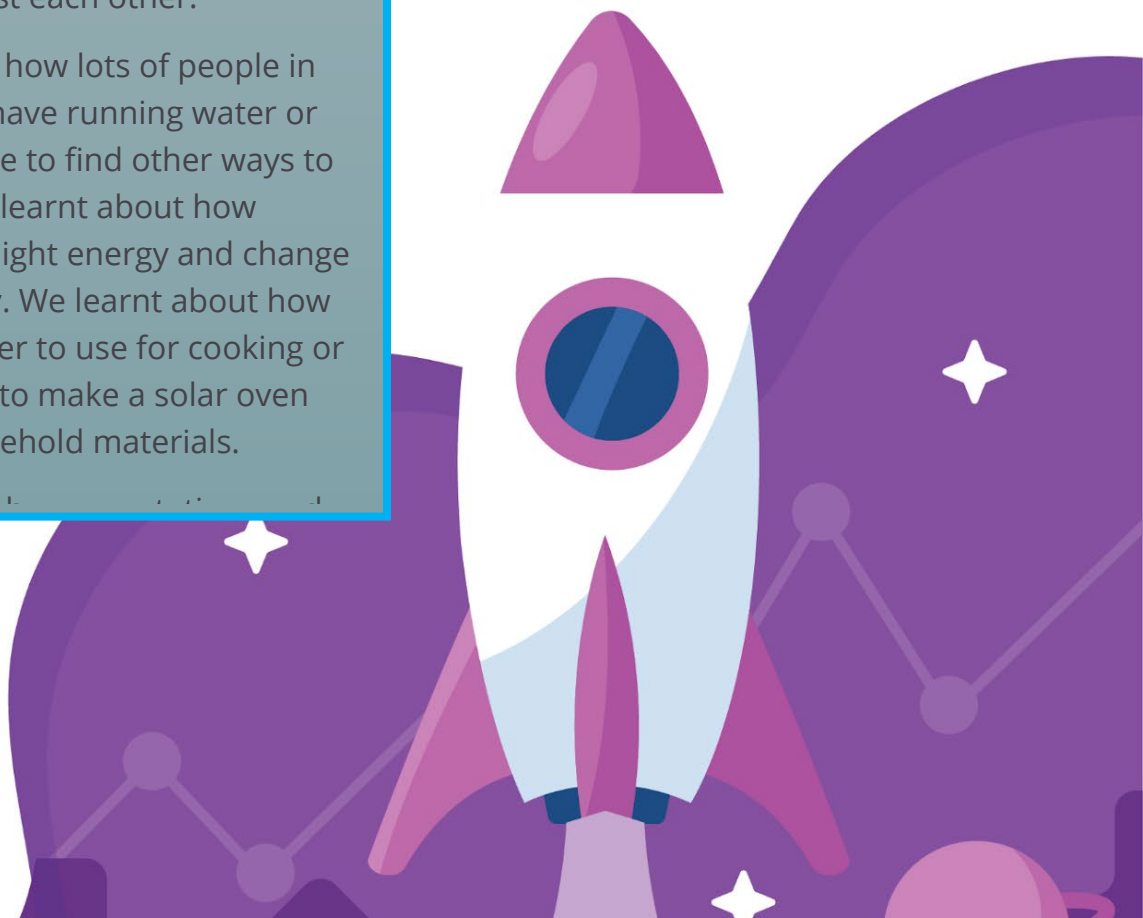



Class 6: Cathedral Catholic Primary School

Our class participated in a STEAM related day of activities with the support of Lancaster and Morecambe College as part of their Erasmus+ school project STEAMitUp.

The College provided us with a selection of resources based on the topic of solar energy and the concept solar cooking. The resources included a lesson plan and an extended workshop outline that we used to guide our activities.

LMC kindly presented the class with a short online introduction to the project and explained what we would be doing throughout the day. Unfortunately, they were unable to participate during the day as we were not allowed to welcome visitors to the school due to the national lockdown.

The day was a great success (despite the lack of actual solar energy) and the groups loved undertaking the different activities and experiments. We had to simplify some of the experiments as they were slightly too advanced for the students. We also did not have all of the necessary resources to complete every stage of the activities, this was due to the



Title	Women in Science: Scratch and HTML
Type	<input type="checkbox"/> Workshop Plan <input type="checkbox"/> Thematic School Day Plan <input checked="" type="checkbox"/> Poster(s) <input checked="" type="checkbox"/> Video <input checked="" type="checkbox"/> Other
Evidence (e.g. video or image)	Video (Makey-Makey.mp4) Images (Cartel_thematic-day.png, Taller de Programacion-1.png, Taller de programacion-2.png) File (STEAMitUp_IO1_Implementation_ES.docx, STEAMitUp_IO1_Implementation_ES.pdf) YouTube Videos (https://www.youtube.com/watch?v=wlcVoFZvtj0 and https://www.youtube.com/watch?v=KLOxIPhK3EM) Final challenge: Breakouts Videos
Content	Within the artefacts

Final challenge: Breakouts





Title	“How can masks prevent the transmission of germs through the air?”
Type	<input checked="" type="checkbox"/> Workshop Plan <input type="checkbox"/> Thematic School Day Plan <input type="checkbox"/> Poster(s) <input type="checkbox"/> Video <input type="checkbox"/> Other
Evidence (e.g. video or image)	Presentation ((PDF file in English and Greek language))
Content	Within the PPT (PDF file)
Title	Covid-19 Mask: “The warrior has his shield...We have our masks!!”
Type	<input type="checkbox"/> Workshop Plan <input type="checkbox"/> Thematic School Day Plan <input type="checkbox"/> Poster(s) <input type="checkbox"/> Video <input checked="" type="checkbox"/> Other
Evidence (e.g. video or image)	Leaflets (PDF file in English and Greek language)
Content	Within the files (Covid-19 Mask leaflet, Sign, Tips, Masks.pdf)
Title	“Building a Balloon Tower”
Type	<input checked="" type="checkbox"/> Workshop Plan <input type="checkbox"/> Thematic School Day Plan <input type="checkbox"/> Poster(s)

	<input type="checkbox"/> Video <input type="checkbox"/> Other
Evidence (e.g. video or image)	Presentation (Balloons-Presentation-ENG.pdf, Balloons-Presentation-GR.pptx, Balloons-Presentation-ENG.pptx)
Content	Within the PPT (PDF file)
Title	“Building a Balloon Tower”
Type	<input type="checkbox"/> Workshop Plan <input type="checkbox"/> Thematic School Day Plan <input type="checkbox"/> Poster(s) <input checked="" type="checkbox"/> Video <input type="checkbox"/> Other
Evidence (e.g. video or image)	Video (Balloons-Video.mp4, Ballons-Video_ENG.mpeg both in English and Greek language, respectively)
Content	Within the Videos (Balloons-Video.mp4, Balloons-Video_ENG.mpeg)
Title	Colorful Cabbage
Type	<input type="checkbox"/> Workshop Plan <input type="checkbox"/> Thematic School Day Plan <input checked="" type="checkbox"/> Poster(s) <input type="checkbox"/> Video <input type="checkbox"/> Other
Evidence (e.g. video or image)	Images (Colorful Cabbage_01-07.jpeg)

Content	Within the Posters
Title	Skittle Rainbows (water, Milk and other candy)
Type	<input type="checkbox"/> Workshop Plan <input type="checkbox"/> Thematic School Day Plan <input checked="" type="checkbox"/> Poster(s) <input checked="" type="checkbox"/> Video(s) <input type="checkbox"/> Other
Evidence (e.g. video or image)	Videos (Skittle Rainbow-water.mp4, Skittle Rainbows_Milk and other candy.mp4) and images (Skittle Rainbow_01-03.jpeg)
Content	Within the Poster and Video
Title	Salt Activities
Type	<input type="checkbox"/> Workshop Plan <input type="checkbox"/> Thematic School Day Plan <input checked="" type="checkbox"/> Poster(s) <input type="checkbox"/> Video <input checked="" type="checkbox"/> Other
Evidence (e.g. video or image)	Images (Salt Sculpture_1-4.jpeg, poster salt.jpg)
Content	Within the Poster and Logbook (Salt_Logbook_English.docx, Salt_logbook_Dutch.docx, Poster_Salt.pdf)

